

2-way Control Valve type G2FMT-SL

Nodular cast iron, PN10, DN100 - 400 mm

0-2.5.31-A

Page 1 of 4



TECHNICAL DATA

Materials:	
- Valve body, slide	Nodular cast iron EN-GJS-400-15
- Sealing element and O-ring	Silicone/PTFE
Flow characteristic	Almost linear
Leakage rate	ANSI class I
Flanges	EN 1092-2 PN 10
- Option	JIS B 2210 5K/10K ANSI class 150
Max. pressure Δp, against which the valve can close	5 bar
Nominal pressure	PN 10
Design temperature	120°C

APPLICATIONS

Control valve type G2FMT-SL is a two way control valve with a slide for quarter turn operation designed for regulating of fresh water, lubricating oil and other liquid media. The valves are designed for use in conjunction with industrial processes, district heating and marine installations with large water or lubricating oil volumes:

- Engine Jacket Cooling Water System
- Lubricating Oil Cooling
- Central Cooling Water System, etc.

The valves are designed for use in conjunction with valve motor type CAR with handle for manual operation or for use in conjunction with a pneumatic actuator type VT.

DESIGN

The valve body and the valve slide are made of nodular cast iron. The valve flanges are drilled according to EN 1092-2 - option JIS B 2210 5K/10k and ANSI class 150.

FUNCTION

The slide is firmly connected with the motor spindle. When the slide is in the one extreme position by turning the spindle, connection A-AB is kept fully open. In the other extreme position connection the valve is fully closed. In the intermediate positions the opening degrees change proportionally. The valve has a small tolerance between body and slide.

This section to be read together with sketches page 2 this data sheet.

FEATURES

- Simple design secures reliable controls and reduces costly downtime
- Most compact valve on the market

Subject to change without notice.

PORT NUMBERING

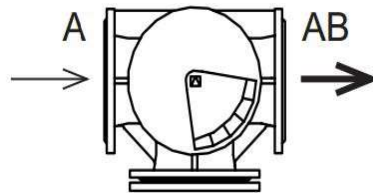

MOUNTING

The valve connections are marked A and AB. Check slide position before installation of the valve. The slide position is marked on the top of the shaft. The valve can be installed with vertical as well as horizontal spindles. The valve must be mounted in a way that the valve actuator will be exposed to a minimum of moisture and unnecessary vibrations.

2-way Control Valve type G2FMT-SL

Nodular cast iron, PN10, DN80 - 400 mm

O-2.5.31-A

Page 3 of 4

DIMENSION SKETCH

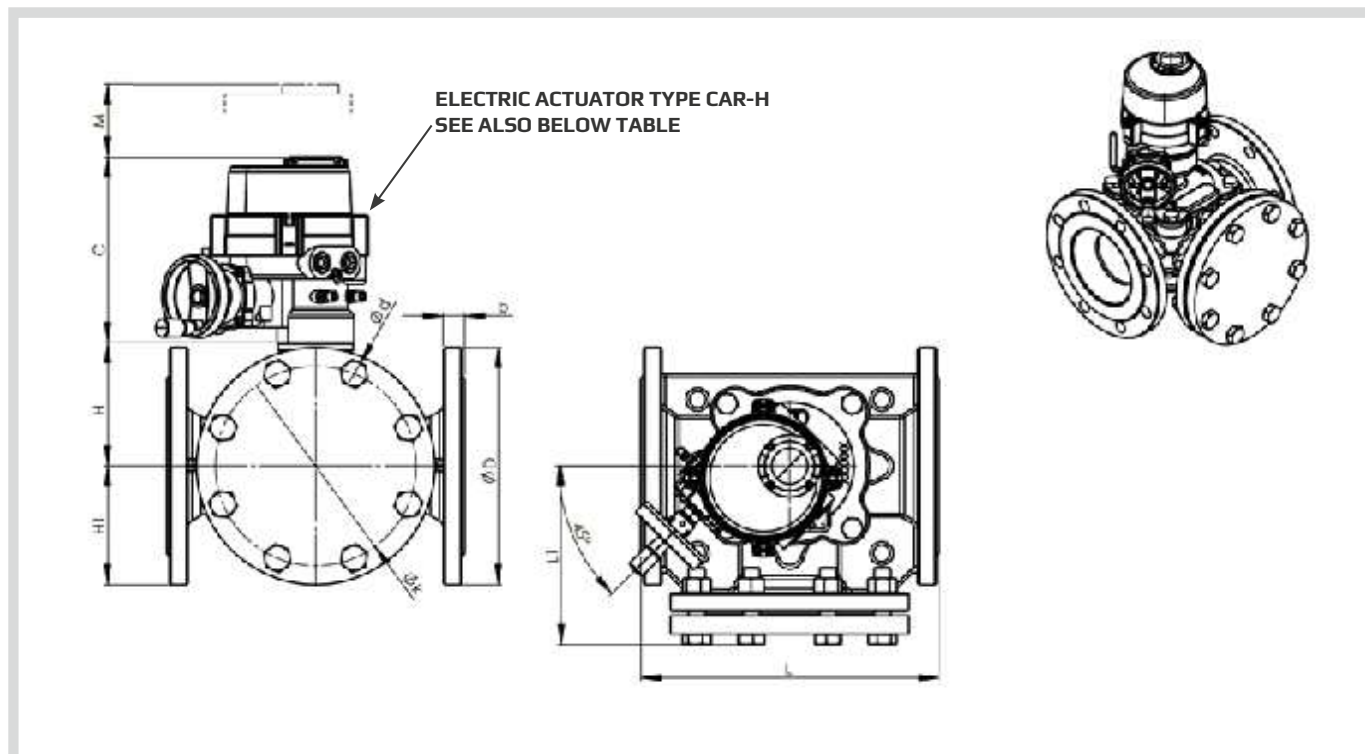

SPECIFICATIONS - TABLE 1 (read this together with table on page 4)

Type	L (mm)	L1 (mm)	H (mm)	H1 (mm)	b (mm)	C1 (mm)	M (mm)	Electric Actuator Type CAR-H
100 G2FMT-SL (*HF)	296	180	140	ØD/2	24	223	110	CAR-H 006/010
125 G2FMT-SL	330	199	140	ØD/2	24	223	110	CAR-H 006/010
125 G2FMT-SL (JIS5K)	320	194	140	ØD/2	19	223	110	CAR-H 006/010
150 G2FMT-SL	356	214,5	149	ØD/2	25,4	223	110	CAR-H 006/010
200 G2FMT-SL	410	243,5	182	ØD/2	28,4	223	110	CAR-H 016
200 G2FMT-SL (**L)	484	280,5	182	ØD/2	28,4	223	110	CAR-H -016
250 G2FMT-SL	480	280,5	202	ØD/2	31	223	110	CAR-H -016
300 G2FMT-SL (**RF)	580	330,5	202	ØD/2	32	223	110	CAR-H 016
300 G2FMT-SL	560	320,5	237	ØD/2	32	261	150	CAR-H -035
350 G2FMT-SL	660	370,5	256	ØD/2	36	261	150	CAR-H 050
400 G2FMT-SL	720	403	278	ØD/2	38	315	180	CAR-H 050

* High Flow
 ** Long Version
 *** Reduced Flow

ØD/2 - Depends on flange type (see also table 2)

Subject to change without notice.

SPECIFICATIONS - TABLE 2

Flange connections	EN 1092-2			ANSI Class 150			JIS B 2210 5K			JIS B 2210 10K		
	D (dia.) (mm)	k (dia.) (mm)	d mm dia. (number)	D (dia.) (mm)	k (dia.) (mm)	d mm dia. (number)	D (dia.) (mm)	k (dia.) (mm)	d mm dia. (number)	D (dia.) (mm)	k (dia.) (mm)	d mm dia. (number)
DN100	220	180	19x(8)	230	191	19x(8)	200	165	19x(8)	210	175	19x(8)
DN125	250	210	19x(8)	255	216	22x(8)	235	200	19x(8)	250	210	23x(8)
DN150	285	240	23x(8)	280	241	22x(8)	265	230	19x(8)	280	240	23x(8)
DN200	343	295	22x(8)	343	298	22x(8)	320	280	23x(8)	330	290	23x(12)
DN250	405	350	23x(12)	405	362	25x(12)	385	345	23x(12)	400	355	25x(12)
DN300	455	400	23x(12)	483	432	25x(12)	430	390	23x(12)	445	400	25x(16)
DN350	505	460	23x(16)	533	476	29x(12)	480	435	25x(12)	490	445	25x(16)
DN400	565	515	28x(16)	597	540	29x(16)	540	495	25x(16)	560	510	27x(16)

SPECIFICATIONS - TABLE 3

Type	Flange connection DN in mm	Kv5 m ³ /h	Torque Nm For inlet P*	Weight kg
DN100 (*HF)	100	259	40	32
DN125	125	259	40	43
DN125 (JIS5K)	125	259	40	43
DN150	150	430	90	53
DN200	200	770	120	85
DN200 (**L)	200	770	120	85
DN250	250	1.230	150	122
DN300 (***)RF)	300	1.190	150	174
DN300	300	2.090	320	162
DN350	350	2.950	418	215 (estimated)
DN400	400	3.760	530	269 (estimated)

*Torque calculated at max Δ P for: DN100 - 300 - 5 Bar

* High Flow

** Long Version

*** Reduced Flow