

3-way Control Valve type L3FM-T

Gun metal, PN16, DN65 - 125mm/ PN10, DN150 - 300mm/ PN6, DN350 - 800mm

O-2.2.10-G

Page 1 of 4



APPLICATIONS

Control valve type L3FM-T is a three-way control valve with a slide for quarter turn operation designed for regulating of sea water. The valves are designed for use in conjunction with valve motor type CAR with handle for manual operation or for use in conjunction with a pneumatic actuator.

DESIGN

The valve body is made of gun metal, while the slide is made of aluminum bronze. The valve flanges are drilled according to EN 1092-2.

FUNCTION

The slide is firmly connected with the actuator spindle. When the slide is in the one extreme position by turning the spindle, connection A-AB is kept fully open and connection B-AB is fully closed. In the other extreme position connection A-AB is fully closed and connection B-AB is fully open. In the intermediate positions the opening degrees change proportionally. The valve has a small tolerance between body and slide. To minimize the leakage an O-ring is mounted in a groove on the slide.

TECHNICAL DATA

Materials:

- Valve body	CuSn10
- Slide	CuAL10Fe5Ni5
- O-ring	NBR 70A
- U-ring	PTFE
- Gasket	AF1000

- Nominal pressure

DN 65-125 L3FM-T PN 16, max. 100°C
(option 120°C)

DN 150-300 L3FM-T

PN 10, max. 100°C
(option 120°C)

DN 350-800 L3FM-T

PN 6, max. 100°C
(option 120°C)

Flow characteristic

Almost
linear

Leakage rate

max 0.5%

Regulating capability

Kvs/Kvr > 25

Flanges

EN 1092-2
PN 6/10 / 16

Counter flanges (suggested)

DIN 2631 - PN 6
DIN 2632 - PN 10
DIN 2633 - PN 16

Max. pressure Δp_L , against which the control can close:

- 65-125 L3FM-T	16 bar
- 150-300 L3FM-T	10 bar
- 350-800 L3FM-T	6 bar

Subject to change without notice.

FEATURES

- Sea water resistant
- Simple design secures reliable controls and reduces costly downtime
- Low leakage rate secures energy savings
- Flexible choice of port placements
- Can be used for both mixing and diverting

PRESSURE/TEMPERATURE DIAGRAM

According to DIN 2401

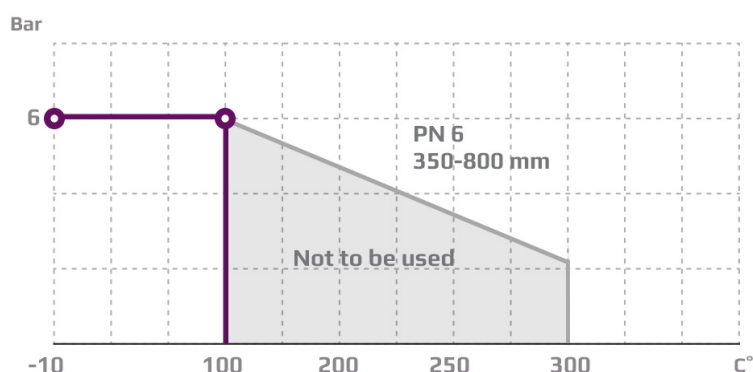

PRESSURE/TEMPERATURE DIAGRAM

According to DIN 2401

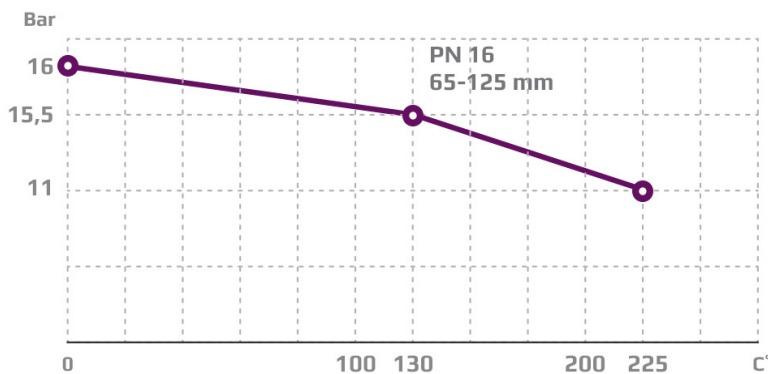
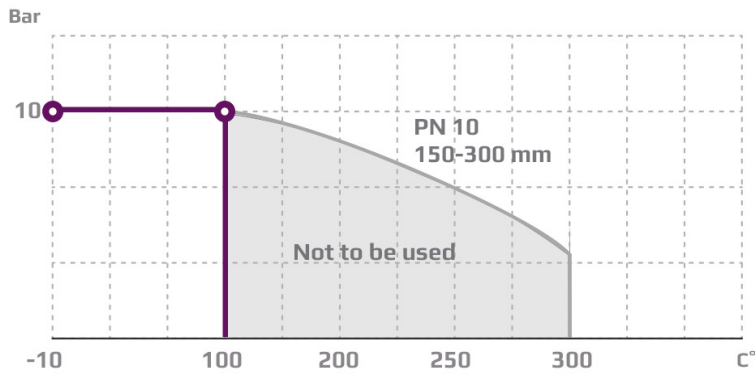

PORT NUMBERING/CONFIGURATION

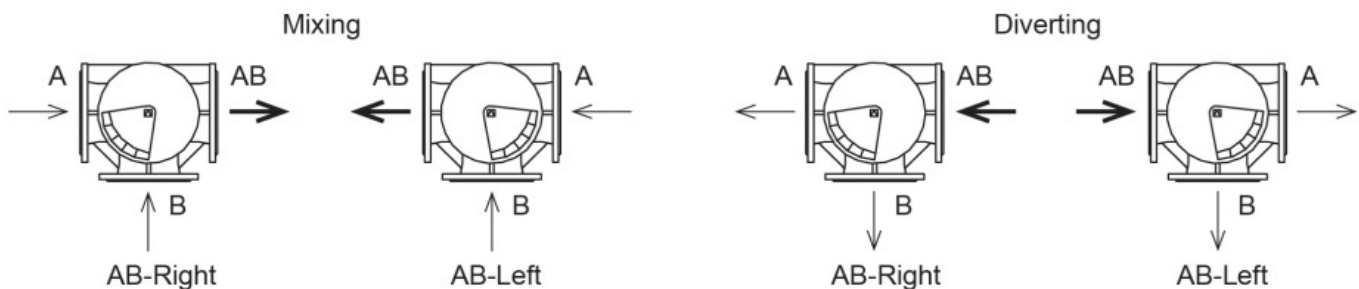

Further specification for ordering (e.g. 400 L3FM-T, AB-Right)

MOUNTING

The valve connections are marked A, B and AB. The slide is operating between A and B. Check slide position before installation in the pipe. The slide position is marked on the top of the shaft. Valve can be supplied in two different configurations, AB-Right and AB-Left. A valve with AB-middle port is available on request. Please note that the supplied configuration is according to installation. The valve can be installed with vertical as well as horizontal spindles. The valve must be mounted in a way that the valve actuator will be exposed to a minimum of moisture and unnecessary vibrations.

3-way Control Valve type L3FM-T

Gun metal, PN16, DN65 - 125mm/ PN10, DN150 - 300mm/ PN6, DN350 - 800mm

O-2.2.10-G

Page 3 of 4

DIMENSION SKETCH

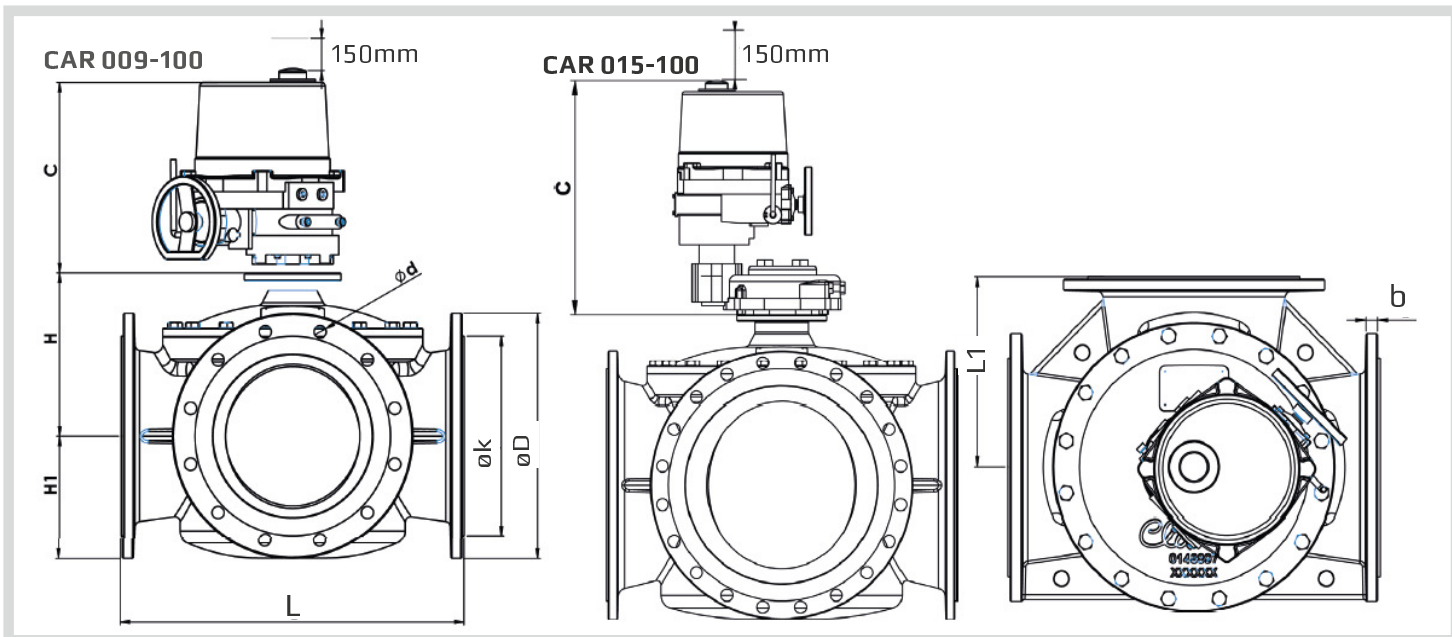

Type	Pressure DN	L mm	L1 mm	H mm	H1 mm	b mm	C mm	EN 1092-2			ANSI Class 150			JIS B 2210 5K			JIS B 2210 10K		
								D (dia.) mm	k (dia.) mm	d mm dia. (number)	D (dia.) mm	k (dia.) mm	d mm dia. (number)	D (dia.) mm	k (dia.) mm	d mm dia. (number)	D (dia.) mm	k (dia.) mm	d mm dia. (number)
65 L3FM-TR	16	292	146	135	90	20	273	185	145	19x(4)	180	140	19x(4)	155	130	15x(4)	175	140	19x(4)
80 L3FM-TR	16	292	146	140	94	20	273	200	160	19x(8)	190	152	19x(4)	180	145	19x(4)	185	150	19x(8)
100 L3FM-TR	16	350	175	158	112	17	273	220	180	19x(8)	230	190.5	19x(8)	200	165	19x(8)	210	175	19x(8)
125 L3FM-TR	16	400	200	179	123	17	273	250	210	19x(8)	255	216	22x(8)	235	200	19x(8)	250	210	23x(8)
150 L3FM-TR	16	438	219	196	139	20	276	285	240	23x(8)	280	241	22x(8)	265	230	19x(8)	280	240	23x(8)
200 L3FM-TR	10	530	270	236	175	21	361	340	295	23x(8)	343	298	22x(8)	320	280	23x(8)	330	290	23x(12)
250 L3FM-TR	10	592	300	273	205	23	361	400	350	23x(12)	405	362	25x(12)	385	345	23x(12)	400	355	25x(12)
300 L3FM-TR	10	649	330	305	230	25.5	361	455	400	23x(12)	483	432	25x(12)	430	390	23x(12)	445	400	25x(16)
350 L3FM-TR	6	717	360	337	255	25.5	361	490	445	23x(12)	534	477	29x(12)	480	435	25x(12)	490	445	25x(16)
400 L3FM-TR	6	770	385	375	285	26	361	540	495	23x(16)	597	540	29x(16)	540	495	25x(16)	560	510	27x(16)
450 L3FM-TR	6	820	410	391	310	26.5	556	595	550	23x(16)	635	578	32x(16)	605	555	25x(16)	620	565	27x(20)
500 L3FM-TR	6	900	455	425	340	27.5	556	645	600	23x(20)	699	635	32x(20)	655	605	25x(20)	675	620	27x(20)
550 L3FM-TR	6	900	455	425	373	27.5	556	-	-	-	-	-	-	720	665	27x(20)	745	680	33x(20)
600 L3FM-TR	6	1000	505	470	393	31.0	556	755	705	28x(20)	813	750	35x(20)	770	715	25x(20)	795	730	33x(24)
650 L3FM-TR	6	1050	525	515	423	35	556	-	-	-	-	-	-	825	770	27x(24)	845	780	33x(24)
700 L3FM-TR	6	1106	553	519	462	34.0	556	860	810	28x(24)	-	-	-	875	820	27x(24)	905	840	33x(24)
800 L3FM-TR	6	1200	600	579	507	37	556	975	920	31x(24)	-	-	-	995	930	32x(24)	1020	950	33x(28)

SPECIFICATIONS

Type	Flange connection DN in mm	k _{vs} -value ¹⁾ Mixing valve m ³ /h	k _{vs} -value ¹⁾ Diverting valve m ³ /h	Torque Nm For inlet P*	Weight kg
65 L3FM-T	65	95	120	46	28
80 L3FM-T	80	122	154	55	32
100 L3FM-T	100	175	220	90	47
125 L3FM-T	125	245	330	150	64
150 L3FM-T	150	395	425	160	75
200 L3FM-T	200	800	1100	250	114
250 L3FM-T	250	1500	2100	395	159
300 L3FM-T	300	2000	2650	550	207
350 L3FM-T	350	2530	3380	640	278
400 L3FM-T	400	3050	3950	895	346
450 L3FM-T	450	3680	4480	1050	433
500 L3FM-T	500	4150	5250	1300	563
550 L3FM-T	550	4150	5250	1300	575
600 L3FM-T	600	4800	6050	1850	816
700 L3FM-T	700	5500	7000	TBC	1150
800 L3FM-T	800	6200	8000	2600	2100

1) kvs-value for port A and B 50% open.

*Torque calculated at max inlet P for:

DN 65 - 125 = 16 Bar

DN 150-300 = 10 Bar

DN 350-800 = 5 Bar

