

# 3-way Control Valve type G3FMT-ULL (Ultra Low Leakage)

Nodular cast iron, PN10, DN100 - 450 mm

O-2.6.15-G

Page 1 of 4

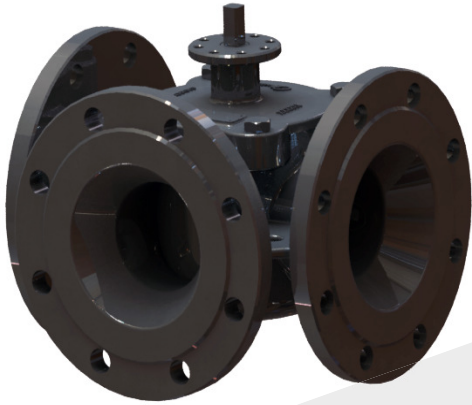

## APPLICATIONS

Control valve type G3FMT-ULL is a three-way control valve with a slide for quarter turn operation designed for regulating of fresh water, lubricating oil and other liquid media. The valves are designed for use in conjunction with industrial processes, district heating and marine installations with large water or lubricating oil volumes:

- Engine Jacket Cooling Water System
- Lubricating Oil Cooling
- Central Cooling Water System, etc.

The valves are designed for use in conjunction with valve motor type CAR with handle for manual operation or for use in conjunction with a pneumatic actuator type VT.

## DESIGN

The valve body and the valve slide are made of nodular cast iron. The valve flanges are drilled according to EN 1092-2 - option JIS B 2210 5K/10K and ANSI class 150.

## FUNCTION

The slide is firmly connected with the motor spindle. When the slide is in the one outer position by turning the spindle, connection A-AB is fully open and connection B-AB is fully closed. In the other outer position connection A-AB is fully closed and connection B-AB is fully open. In the intermediate positions the opening degrees change proportionally. The valve has a small tolerance between body and slide. PTFE sealing element and O-ring are mounted in the slider groove to minimize leakage.

Connection described for AB-Left valves - reverse connection for AB-Right valves.

This section to be read together with sketches page 2 this data sheet.

## TECHNICAL DATA

<b>Materials:</b>	
- Valve body, slide	Nodular cast iron EN-GJS-400-15
- Sealing element and O-ring	Silicone/PTFE
<b>Flow characteristic</b>	Almost linear
<b>Leakage rate</b>	ANSI class IV/EN 1349 < 0.01%
<b>Flanges</b>	EN 1092-2 PN 10
- Option	JIS B 2210 5K/10K ANSI class 150
<b>Max. pressure <math>\Delta p</math>, against which the valve can close</b>	5 bar
<b>Nominal pressure</b>	PN 10
<b>Design temperature</b>	120°C
<b>Optional temperature</b>	150°C

## FEATURES

- Simple design secures reliable controls and reduces costly downtime
- Ultra Low Leakage rate secures energy savings - Best in class
- Most compact valve on the market
- Full flexibility on port orientation on AB right or AB left

Subject to change without notice.

[www.cloriuscontrols.com](http://www.cloriuscontrols.com)

**PORT NUMBERING: AB-RIGHT**

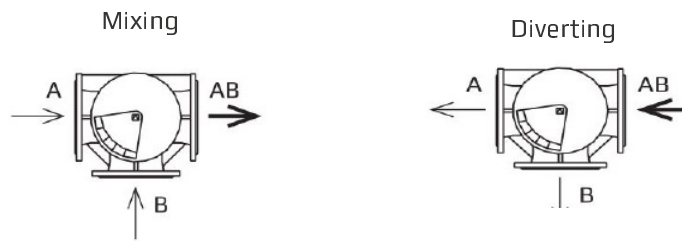

**PORT NUMBERING: AB-LEFT**

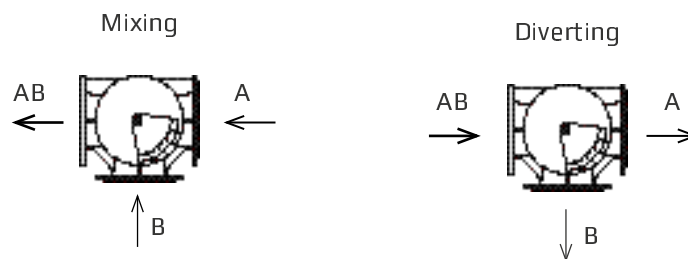

**MOUNTING**

The valve connections are marked A, B and AB. The slide is operating between A and B. Check slide position before installation in the pipe. The slide position is marked on the top of the shaft. The valves can be installed with vertical as well as horizontal spindles. The valves must be mounted in a way that the valve actuator will be exposed to a minimum of moisture and unnecessary vibrations.

# 3-way Control Valve type G3FMT-ULL (Ultra Low Leakage)

Nodular cast iron, PN10, DN100 - 450 mm

0-2.6.15-G

Page 3 of 4

## DIMENSION SKETCH

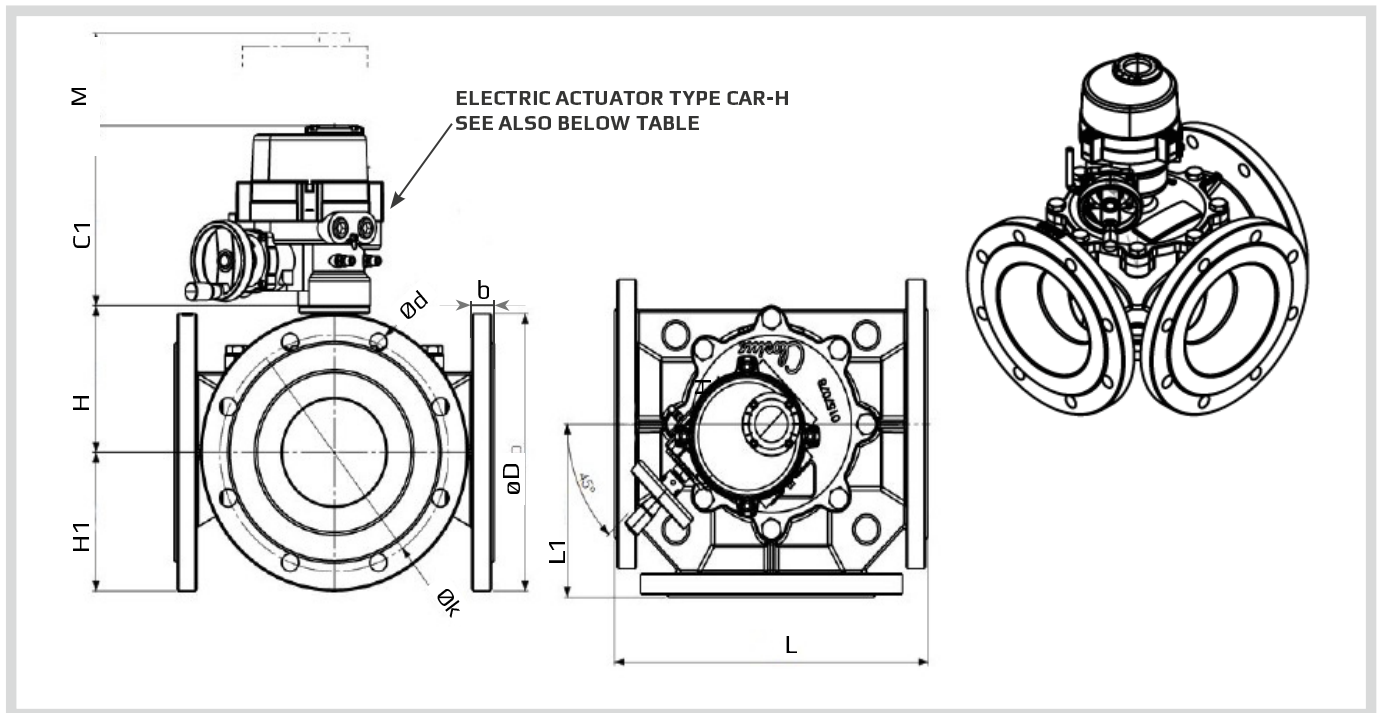

**SPECIFICATIONS - TABLE 1** (read this together with table on page 4)

Type	L (mm)	L1 (mm)	H (mm)	H1 (mm)	b (mm)	C1 (mm)	M (mm)	Electric Actuator Type CAR-H
100 G3FMT-ULL (*HF)	296	148	140	ØD/2	24	223	110	CAR-H 006/010
125 G3FMT-ULL	330	165	140	ØD/2	24	223	110	CAR-H 006/010
125 G3FMT-ULL (JIS5K)	320	160	140	ØD/2	19	223	110	CAR-H 006/010
150 G3FMT-ULL	356	178	149	ØD/2	25,4	223	110	CAR-H 006/010
200 G3FMT-ULL	410	205	182	ØD/2	28,4	261	150	CAR-H 016
200 G3FMT-ULL (**L)	484	242	182	ØD/2	28,4	261	150	CAR-H -016
250 G3FMT-ULL	480	240	202	ØD/2	31	261	150	CAR-H -016
300 G3FMT-ULL (**RF)	580	290	202	ØD/2	32	261	150	CAR-H 016
300 G3FMT-ULL	560	280	237	ØD/2	32	315	180	CAR-H -035
350 G3FMT-ULL	660	330	256	ØD/2	36	315	180	CAR-H 050
400 G3FMT-ULL	720	360	278	ØD/2	38	315	180	CAR-H 050
450 G3FMT-ULL	780	390	314	ØD/2	26	352	195	CAR-H 080

\* High Flow

\*\* Long Version

\*\*\* Reduced Flow

ØD/2 - Depends on flange type (see also table 2)

Subject to change without notice.

SPECIFICATIONS - TABLE 2

Flange connections	EN 1092-2			ANSI Class 150			JIS B 2210 5K			JIS B 2210 10K		
	D (dia.) (mm)	k (dia.) (mm)	d mm dia. (number)	D (dia.) (mm)	k (dia.) (mm)	d mm dia. (number)	D (dia.) (mm)	k (dia.) (mm)	d mm dia. (number)	D (dia.) (mm)	k (dia.) (mm)	d mm dia. (number)
DN100	220	180	19x(8)	230	191	19x(8)	200	165	19x(8)	210	175	19x(8)
DN125	250	210	19x(8)	255	216	22x(8)	235	200	19x(8)	250	210	23x(8)
DN150	285	240	23x(8)	280	241	22x(8)	265	230	19x(8)	280	240	23x(8)
DN200	343	295	22x(8)	343	298	22x(8)	320	280	23x(8)	330	290	23x(12)
DN250	405	350	23x(12)	405	362	25x(12)	385	345	23x(12)	400	355	25x(12)
DN300	455	400	23x(12)	483	432	25x(12)	430	390	23x(12)	445	400	25x(16)
DN350	505	460	23x(16)	533	476	29x(12)	480	435	25x(12)	490	445	25x(16)
DN400	565	515	28x(16)	597	540	29x(16)	540	495	25x(16)	560	510	27x(16)
DN450	620	565	28x(20)	620	578	32x(16)	620	555	25x(16)	620	565	27x(20)

SPECIFICATIONS - TABLE 3

Type	Flange connection DN in mm	KvS m <sup>3</sup> /h**	Torque Nm For inlet P*	Weight kg
DN100 (*HF)	100	270	40	27.9
DN125	125	260	40	34
DN150	150	430	90	42
DN200	200	770	120	67
DN250	250	1.230	150	95
DN300 (***RF)	300	1.190	150	140
DN300	300	2.030	320	130
DN350	350	2.850	418	175
DN400	400	3.760	530	220
DN450	450	4.600	654	227

\*Torque calculated at max  $\Delta P$  for: DN100 - 450 - 5 Bar

\*\*NOTE: KvS is max. KvS value