

Pressure Differential Controls

Type TDS

0-3.9.02-E

Page 1 of 2



TECHNICAL DATA

Materials:	
- Valve body	Hot-pressed brass (W. no. 2.0400-ASTM B283)
- Seat and cone	Stainless steel (W. no. 1.4305-AISI 303)
- Diaphragm housing	Nodular cast iron EN-GJS-400-15 (W. no. 0.7040 -ASTM A395)
- Diaphragm	EPDM rubber with web reinforcement (ASTM D2000)
- Capillary	Copper (ASTM B42) 2x1 m
Type of valve	Single seated
Flow characteristic	Linear (approx.)
Weight, incl. valve	2.5 kg

APPLICATIONS

The TDS controllers, which are made in four variants, have the following major applications:

Control of differential pressure, noise and dynamic balance. In individual users circuits and sub-mains within a large distribution network. For example in District Heating or Group Heating networks. Control of by-pass between flow and return where 3-way valves or 2-way zone control valves are installed. To limit volume variations and maximum Δp . Similarly for low water content boilers and devices requiring a minimum circulation irrespective of load conditions. With the addition of a miniature solenoid valve in the impulse connection the valve can also be used to isolate a circuit with respect to time or temperature.

FUNCTION

The TDS controller can be installed in either the flow or return of the sub-circuits.

The high pressure line is connected to the adjustment side of the diaphragm housing and the low pressure line to the valve body side of the diaphragm. Any change of differential pressure across the diaphragm - which is connected to the valve mechanism - above or below the set point will cause the diaphragm to change its position. If higher than set pressure the valve will move to close, if lower than set pressure the valve will move to open, until the system is once again in balance. Adjustment of the differential pressure setting is made by rotating the adjusting handle clockwise or anticlockwise until the desired set point is reached (see diagram). The upper edge of the adjustment cap in conjunction with the scale marked on the spring guide tube is an indication of the actual setting. The scale moves into or out of the handle loading the valve and diaphragm. The set pressure is shown on a percentage scale in 10% increments.

DESIGN

The TDS controller is a spring loaded self-acting proportional controller consisting of a valve, a diaphragm and housing and two capillary tubes on either side of the diaphragm.

The valve body, available in DN15 and DN20, is made of hot-pressed brass, and the seat and cone of stainless steel. The diaphragm housing is made of nodular cast iron, and the diaphragm itself is made of EPDM rubber with web reinforcement. If required, the TDS controller adjustment handle can be sealed, preventing unauthorised persons from altering the set point.

FEATURES

- Good regulating accuracy
- Nominal pressure PN 16
- Max. temperature 150°C
- Self-acting
- Low-noise control.

Subject to change without notice.

INSTALLATION

According to the conditions, the TDS controller can be built into either the return pipe or the flow pipe in a suitable position. The diaphragm area is large enough to give a sensitive response to small pressure variations; it is designed to be a compact controller without sacrificing performance.

RELATION BETWEEN SCALE SETTING AND DIFFERENTIAL PRESSURE

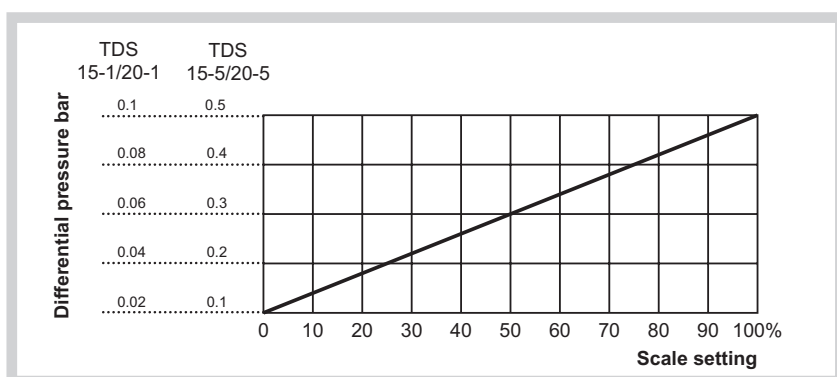

DIMENSION SKETCH

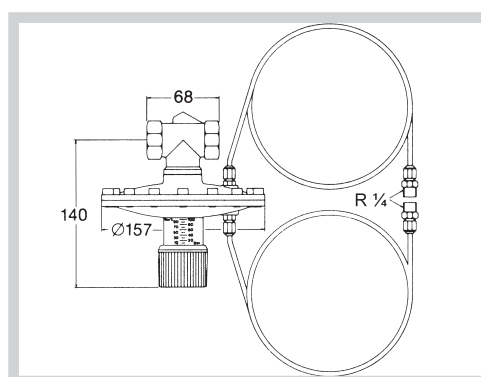

SIZING CHART

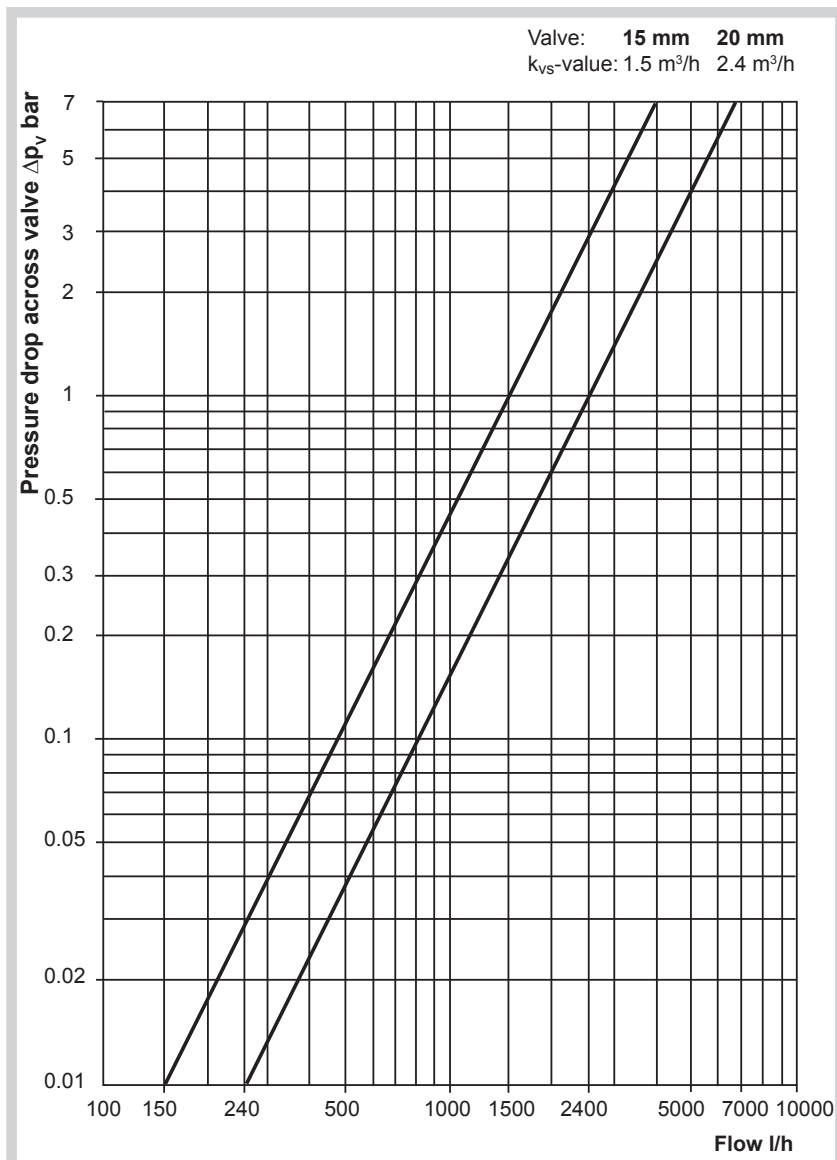

Type	TDS			
	TDS15-1	TDS15-5	TDS20-1	TDS20-5
Setting range bar	0.02-0.1	0.1-0.5	0.02-0.1	0.1-0.5
Proportional band mbar	16	80	16	80
Max. thrust on stem N	200		200	
Nom. pressure PN bar	16		16	
Max. rated travel mm	7		7	
Max. temp. of liquid °C	130 (150) ¹⁾		131 (150) ¹⁾	
Note	Incl. hot pressed brass valve, Rp 1/2 k vs =1.5, Δp L =7 bar		Incl. hot pressed brass valve, Rp 3/4 k vs =2.4, Δp L =7 bar	

The max. pressure against which the controls can close Δp_L depends on the valves and it is stated above. To avoid noise problems it is recommended that the pressure drop across valve Δp_v does not exceed 1 bar in living quarters.
¹⁾ 150°C - Only if TD controller is installed below the valve.