

Duostats

Self-acting Temperature Controls

O-3.5.01-F

Page 1 of 4

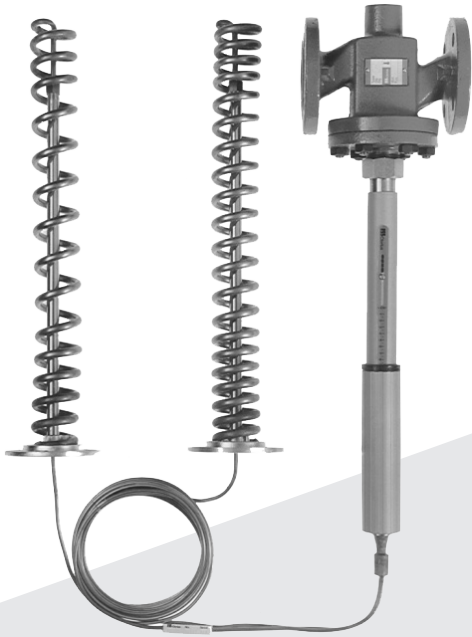

TECHNICAL DATA

Closing force	500 N
Capillary length	3m to 21m
Neutral zone	1,5°C - 2,5°C
Temperature range	0 to 160°C (-30 to 280°C on request)

For linear valves up to DN150
For heating or cooling valves

CLORIUS DUOSTATS

Duostats are thermostats, type V, which via two sensing elements in a common hydraulic system act on one and the same control valve.

Two basic types are available: V4.05 or V4.10, depending on the preferable proportional band PB, and the valve size.

For quick and accurate valve selection and valve sizing, we advise you to visit our website www.cloriuscontrols.com and select our sizing software Quick Choice 4.

The sensing elements are two spiral sensors for the ventilation duct or two rod sensors (a combination of one spiral sensor and one rod sensor may be supplied in certain combinations). The effect, which the two sensing elements have on the adjustment, is proportional to the liquid volume of the individual sensors. Duostats are therefore available with varying proportions between the liquid volumes of the two sensors (sensor proportions) and in that way they can meet the requirements made by a number of different adjustment problems. As the adjustment result is a weighted average value of the temperatures of the two sensors, no fixed adjustment value can be indicated. Hence, Duostats are not equipped with a temperature scale, but with a marking for adjustment towards higher or lower temperatures, respectively.

APPLICATIONS

1. Adjustment of discharge air temperatures in hot-air heating plants, dependent on the outdoor temperature.
2. Adjustment of two temperatures which are interdependent. E.g. the hot-water tank of a district heating plant with simultaneous control that the return water temperature does not become too high.

FEATURES

- No external power required.
- For use in hazardous area.
- Simple design secures reliable controls and reduces costly downtime.
- Customizable, User friendly, Plug & Control.
- No special tools needed for service.
- Low installation cost.

SELECTION OF DUOSTAT TYPES

For quick and accurate valve selection and valve sizing, we advise you to visit our website www.cloriuscontrols.com and select our sizing software Quick Choice 4.

Subject to change without notice.

APPLICATIONS

Air Heating Plants

For air heating plants Duostats with two spiral sensing elements for air ducts are used. **Fig. 1** shows an example of a plant with Duostat. The primary sensor V_p (red) is the real control sensor which goes into the controlled system. The secondary sensor V_s (blue) which is located outside the controlled system, registers the outdoor temperature and determines the necessary air temperature by V_p . If there is no supply air duct, where the secondary sensor can be built in, it can be placed in free air. For this purpose a wall bracket is available. In order to determine the correct Duostat, use diagram A where the combinations of spiral sensors for air ducts are found on the left hand.

Other Applications

Duostats are sometimes used for purposes where both sensing elements go into the same controlled system (see examples 2 and 3). The controlled condition will then be a weighted average of the registrations of the two sensors, as shown in the following examples.

In **fig. 2** a hot-water tank connected to district heating is adjusted by a Duostat whose one sensor - the primary sensor - controls the temperature of the tank which should be constant. The secondary sensor registers the temperature of the water which is led back to the district heating network. It secures that the valve does not open so much that the temperature of the return water rises in an uncontrolled manner, when a large water consumption reduces the temperature in the tank.

Fig. 3 shows a room heated by hot air. The primary sensor is built into the extract air duct in order to serve as a room thermostat from this place. The secondary sensor is built into the discharge air duct where it counteracts that the discharge air temperature becomes too low - which would feel like a draught - when the room temperature rises as a result of the heat development which may come from persons or heating processes in the room.

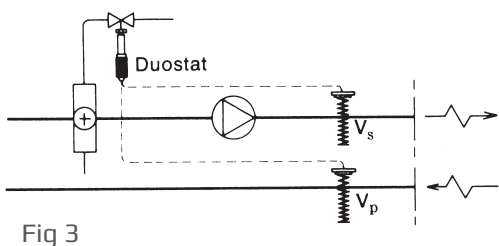
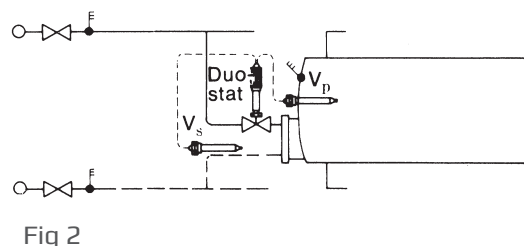
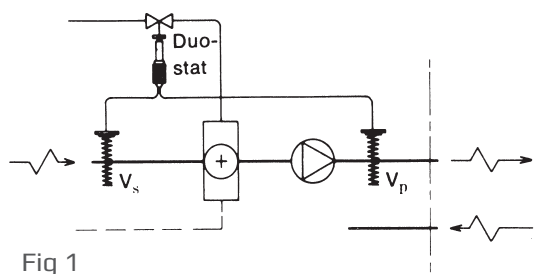



THEORETICAL BASIS

The theoretical basis for the use of Duostats for room heating plants rests on the balance between the heat brought to the plant, and the thermal loss from the heated rooms to the surroundings. By hot-air plants (**fig. 1**) this may approximately be expressed by equation 1), but with small changes, these considerations may be applied to central heating plants with water as the heat carrier.

$$1) Lc_p (t_i - t_u) = \Sigma kf(t_r - t_u)$$

Here L is the quantity of air which is heated from the outdoor temperature t_u to the discharge temperature t_i , and c_p is the specific heat of the air. $k \cdot f$ expresses the sum of transmission surfaces, joints, etc., through which heat is lost to the surroundings by the difference between the temperatures of the heated rooms t_r and the outdoor temperature t_u . As L, c_p , $k \cdot f$ and the room temperature are constant sizes, equation 1) can be converted into:

$$2) (t_{i \max} - t_{i \min}) / (t_{u \max} - t_{u \min}) = \Delta t_i / \Delta t_u = n$$

Here $t_{i \max}$ and $t_{u \min}$ are belonging values for the calculated discharge air temperature by the outdoor temperature for which the plant has been dimensioned. In the same way, $t_{i \min}$ and $t_{u \max}$ are interbelonging values by the condition where the thermal loss is 0 (normally 20°C). The size n expresses how many degrees t_i has to be raised, when t_u falls one degree. It is constant for the individual plant, but varies from plant to plant. This problem can be met by supplying the Duostats with different sensor proportions. The proportion between the liquid volume in secondary and primary sensors is:

$$3) V_s / V_p = 1.25n$$

This formula is approximate, as the expansion coefficient of the liquid (glycerine) varies with the temperature, which is compensated for with the factor 1.25.

ORDER DIAGRAM

By specifications of Duostats, the following information is given:

1. Valve. Dimension and type	Example 15 M1F
2. Duostat. Basic type and sensor proportion	V4.05 C
3. Capillary tube from adjusting cylinder to secondary sensor (Vs, blue)	6 m
4. Capillary tube from adjusting cylinder to primary sensor (Vp, red)	3 m

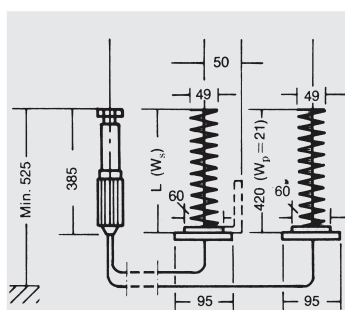

Type		V4.05 A	V4.05 B	V4.05 C	V4.05 D	V4.05 E
Closing power	N	500	500	500	500	500
Length of secondary sensor L	mm	430	430	430	430	430
Secondary sensor's windings W_s		7	10	14	21	29
Secondary sensor's time constant *	sec.	360	360	360	360	360
Primary sensors's time constant *	sec.	360	360	360	360	360
Sensor proportion $V_s : V_p$		0.35:1	0.5:1	0.7:1	1:1	1.4:1
Excess temperature protector	°C	80	80	80	80	80
Max. lifting height	mm	21	21	21	21	21
Travel	mm/°C	0.5	0.5	0.5	0.5	0.5

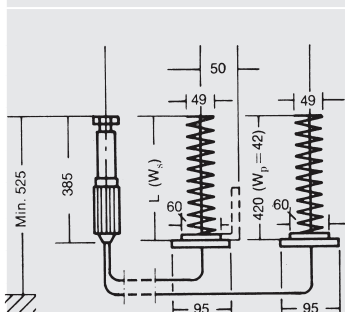

Type		V4.10 A	V4.05 B	V4.05 C	V4.05 D	V4.05 E
Closing power	N	500	500	500	500	500
Length of secondary sensor L	mm	430	430	430	430	430
Secondary sensor's windings W_s		14	21	29	42	42
Secondary sensor's time constant *	sec.	360	360	360	360	360
Primary sensors's time constant *	sec.	360	360	360	360	360
Sensor proportion $V_s : V_p$		0.35:1	0.5:1	0.7:1	1:1	1.45:1
Excess temperature protector	°C	40	40	40	40	40
Max. lifting height	mm	21	21	21	21	21
Travel	mm/°C	1	1.0	1.0	1.0	1.0

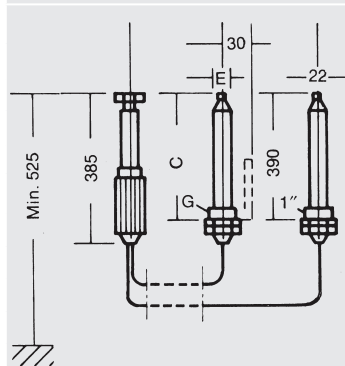

Type		V4.05 L	V4.05 M
Closing power	N	500	500
Length of secondary sensor C	mm	390	490
Secondary sensor's diam. E	mm	22	28
Secondary sensor's thread conn. G	ISO 7/1	R1	R1
Secondary sensor's time constant*	sec.	130	165
Primary sensor's time constant	sec.	130	130
Sensor proportion $V_s : V_p$		1:1	2:01
Excess temperature protector	°C	0:00	80
Max. lifting height	mm	21	21
Travel	mm/°C	0.5	0.5

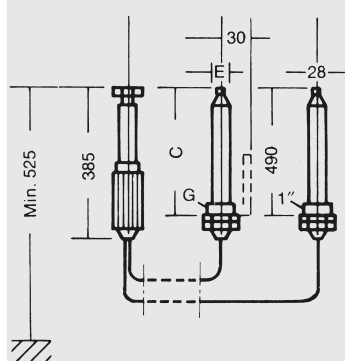

Type		V4.10 L	V4.10 N
Closing power	N	500	500
Length of secondary sensor C	mm	490	800
Secondary sensor's diam. E	mm	28	34
Secondary sensor's thread conn. G	ISO 7/2	R1	R2
Secondary sensor's time constant*	sec.	165	280
Primary sensor's time constant	sec.	165	165
Sensor proportion $V_s : V_p$		1:1	2.9:1
Excess temperature protector	°C	0:00	40
Max. lifting height	mm	21	21
Travel	mm/°C	1	1.0

*The time constants are for spiral sensing elements for air ducts measured in air with a velocity of 4 m/sec. For rod sensing elements they are measured in water with a velocity of 1 m/sec.