

# 3-way Control Valve type G3FA

Nodular cast iron, PN16, DN 80 – 300 mm / PN10, DN300/250 mm

0-2.5.16-A

Page 1 of 2



## APPLICATIONS

Control valves type G3FA are designed for regulating of fresh water, lubricating oil and other liquid media. The valves are designed for use in conjunction with large industrial processes, district heating and marine installations, e.g. cooling of main and auxiliary en-gines. Is used in conjunction with Clorius valve motor type AVM/AVF 234 or Clorius pneumatic actuators.

## DESIGN

The valve components (seats and cone) are made of alubronze, the spindle of stainless steel. The valve body is made of nodular cast iron and the valve flanges are drilled according to EN 1092-2 (JIS B 2210 option). Tight between port 1(AB) og 3(B) is optional.

## FUNCTION

The valve cone is firmly connected with the motor spindle. When the valve cone is in the one extreme position by draw on the spindle, connection A-AB is kept fully open and connection B-AB is fully closed. In the other extreme position connection A-AB is fully closed and connection B-AB is fully open. In the intermediate positions the opening degrees change proportionally.

## TECHNICAL DATA

### Materials:

- Valve body	Nodular cast iron EN-GJS-400-15
- Seats and cone	Alu Bronze CuAL10Fe5Ni5
- Spindle	Stainless steel (W.no 1.4436)
- O-ring	A75H
- Gasket	Reinz-AFM34
<b>Nominal pressure</b>	
- 80-200 G3FA:	PN 16 (max.120/160°C)
- 300/250-300 G3FA:	PN 10 (max 120/160°C)
- 80-300 G3FA:	JIS 10K (option)
<b>Seats</b>	2 balanced single seats
<b>Flow characteristic</b>	Almost linear
<b>Leakage rate</b>	≤ 0.5%
<b>Regulating capability</b>	Kvs/Kvr > 25
<b>Flanges</b>	According to EN 1092-2, PN 16 & PN 10
- Option:	According to JIS B 2210 10K

### Note !

Valve type 200/175 G3FA has outer measures and flanges drilled as valve type 200 G3FA. Valve type 300/250 G3FA has outer measures and flanges drilled as valve type 300 G3FA.

### Counter flanges (suggested for EN 1092-2)

- 80-200 G3FA:	DIN 2633 – PN 16
- 300/250-300 G3FA:	DIN 2632 – PN 10

### For cooling and heating purposes

#### Important note

In case the valves are applied as diverting valves, the pressure drop will increase by 35% and the kvs-value will decrease by 14% as against mixing valves.

Subject to change without notice.

## FEATURES

- Can be used for both mixing and diverting
- Simple design secures reliable controls and reduces costly downtime.
- Location of the pack box in the actuator makes the valve service friendly

## PRESSURE/TEMPERATURE DIAGRAM

According to DIN 2401

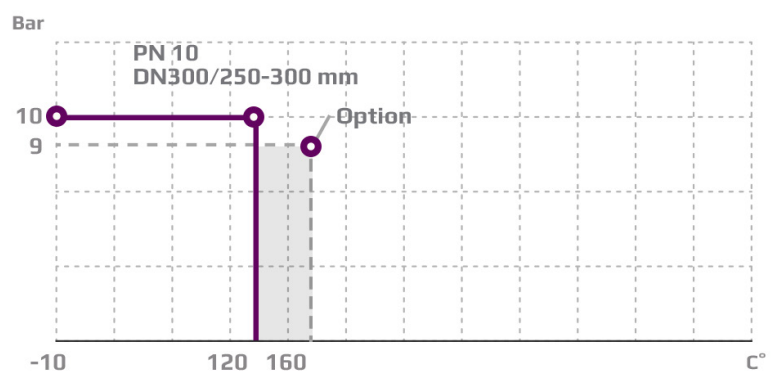
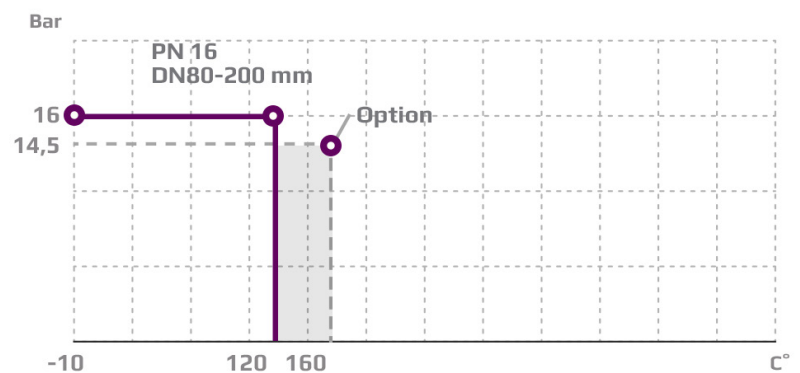

### PORT NUMBERING

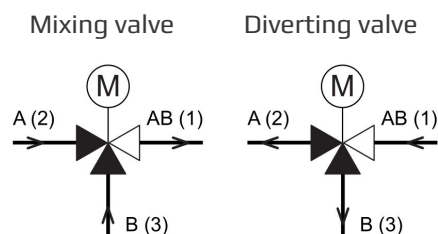

Port AB (1)  
Port A (2)  
Port B (3)

common port always open  
closes at load on spindle  
opens at load on spindle



### MOUNTING

The valves can be installed vertical as well as horizontal. The valves must be mounted in a way that the valve motor will be exposed to a minimum of moisture and unnecessary vibrations. Free height above / below the valve must be minimum 400 mm for mounting and operation of the AVM/AVF 234 motor, otherwise minimum 745 mm for pneumatic actuators.

### DIMENSION SKETCH

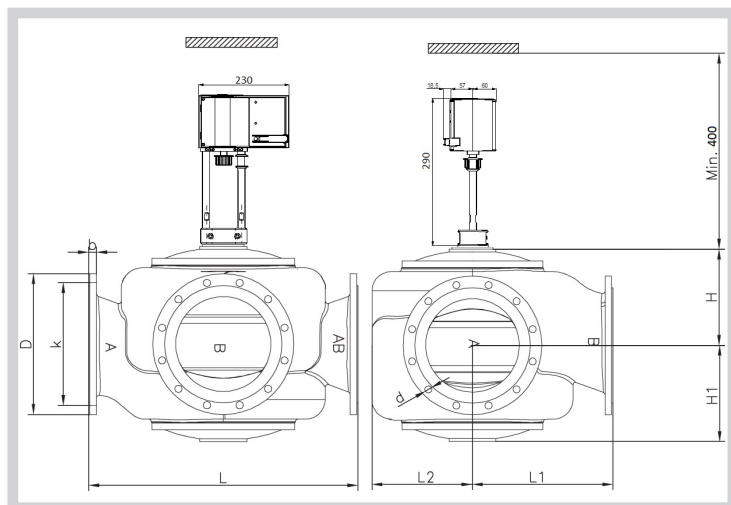

### SPECIFICATIONS

Type	Flange connection DN in mm	Opening mm	$k_{vs}$ -value <sup>1)</sup> m <sup>3</sup> /h	Lifting height mm	Weight kg
80 G3FA	80	80	80	11	35
100 G3FA	100	100	125	13	44
125 G3FA	125	125	215	18	72
150 G3FA	150	150	310	20	111
200/175 G3FA	200	200	425	22	165
200 G3FA	200	200	555	28	160
300/250 G3FA	300	300	865	28	306
300 G3FA	300	300	1250	45	290

1) The stated kvs values apply for mixing valves. Diverting valves: 0.86 x (kvs-values for mixing valves).

Type	L mm	L1 mm	L2 mm	H mm	H1 mm	b mm	EN 1092-2			JIS B 2210 10		
							D (dia.) mm	k (dia.) mm	d mm dia. (number)	D (dia.) mm	k (dia.) mm	d mm dia. (number)
80 G3FA	310	155	102	117	127	19	200	160	19x(8)	185	150	19x(8)
100 G3FA	350	175	112	132	141	19	220	180	19x(8)	210	175	19x(8)
125 G3FA	400	240	138	181	171	19	250	210	19x(8)	250	210	23x(8)
150 G3FA	480	270	165	216	189	24	285	240	23x(8)	280	240	23x(8)
200/175 G3FA	600	325	230	238	238	20	340	295	23x(12)	330	290	23x(12)
200 G3FA	600	325	230	238	238	20	340	295	23x(12)	330	290	23x(12)
300/250 G3FA	850	450	325	305	305	25	445	400	23x(12)	445	400	25x(16)
300 G3FA	850	450	325	305	305	25	445	400	23x(12)	445	400	25x(16)