

2-way Control Valve type G2FM-T

Nodular cast iron PN 25, DN 65-125 mm / PN 16, DN 125 – 300 / PN 10, DN 350 – 600 mm

0-2.5.05.01-D

Page 1 of 4



APPLICATIONS

Control valve type G2FM-T is a two-way control valve with blocked port making a two-way control valve. The slide for quarter turn operation designed for regulating of fresh water, lubricating oil and other liquid media. The valves are designed for use in conjunction with industrial processes, district heating and marine installations with large water or lubricating oil quantities. The valves are designed for use in conjunction with valve motor type CAR with handle for manual operation or for use in conjunction with a pneumatic actuator.

DESIGN

The valve body and the valve slide are made of nodular cast iron. The valve flanges are drilled according to EN 1092-2 or ANSI Class 150.

FUNCTION

The slide is firmly connected with the motor spindle. When the slide is in the one extreme position by turning the spindle, connection A-AB is kept fully open. In the other extreme position connection the valve is fully closed. In the intermediate positions the opening degrees change proportionally. The valve has a small tolerance between body and slide. To minimize the leakage an O-ring is mounted in a groove on the slide.

TECHNICAL DATA

Materials:

- Valve body, slide	Nodular cast iron EN-GJS-400-15
- O-ring	NBR 70A
- Nuts, bolts	24 CrMo 5/A4
- U-ring	PTFE

Nominal pressure

- DN 65-120	PN 25, max. 100°C (option 250°C)
- DN 150-300	PN 16, max. 100°C (option 250°C)
- DN 350-600	PN 10, max. 100°C (option 250°C)

Flow characteristic

Almost linear

Leakage rate

Max. 0.5%

Regulating capability

Kvs/Kvr > 25

Flanges

EN 1092-2
PN 10/16/25

Counter flanges (suggested)

ANSI Class 150
DIN 2632 – PN 10
DIN 2633 – PN 16
DIN 2634 – PN 25

Max. pressure Δp_L , against which the control can close:

- DN 65-125	25 bar
- DN 150-300	16 bar
- DN 350-600	10 bar

FEATURES

- Simple design secures reliable controls and reduces costly downtime.
- Low leakage rate secures energy savings and avoids overheating.

PRESSURE/TEMPERATURE DIAGRAM

According to DIN 2401

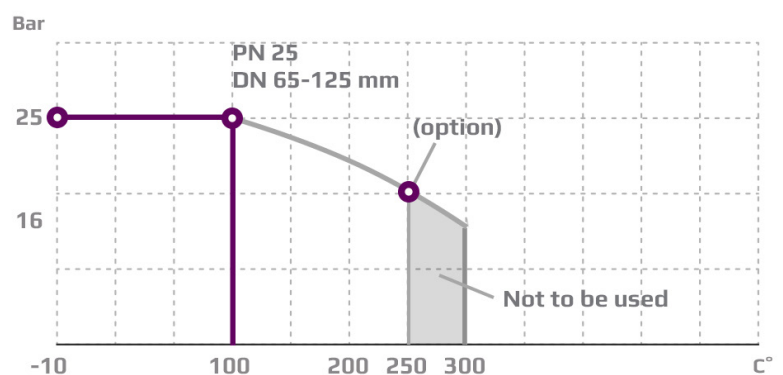

PRESSURE/TEMPERATURE DIAGRAM

According to DIN 2401

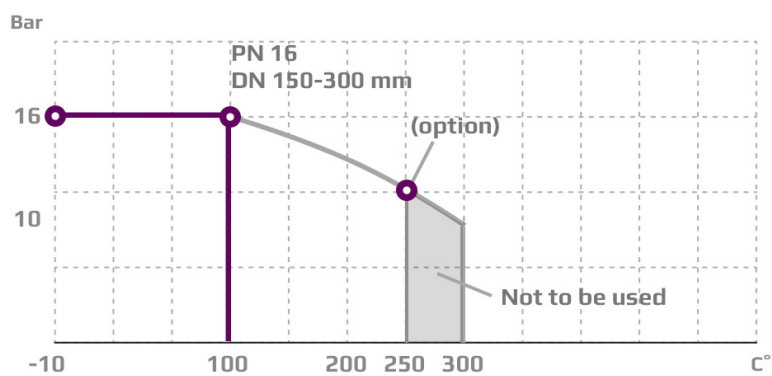

* DN125 available on request in PN16

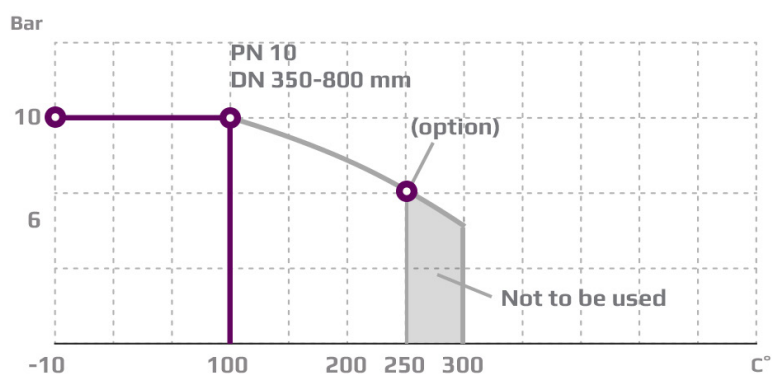

PORT NUMBERING

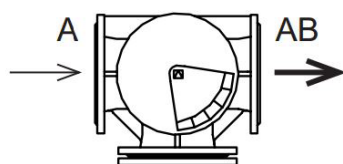

MOUNTING

The valve connections are marked A and AB. Check slide position before installation of the valve. The slide position is marked on the top of the shaft. The valve can be installed with vertical as well as horizontal spindles. The valve must be mounted in a way that the valve actuator will be exposed to a minimum of moisture and unnecessary vibrations.

2-way Control Valve type G2FM-T

Nodular cast iron PN 25, DN 65-125 mm / PN 16, DN 150 – 300 / PN 10, DN 350 – 600 mm

0-2.5.05.01-D

Page 3 of 4

DIMENSION SKETCH

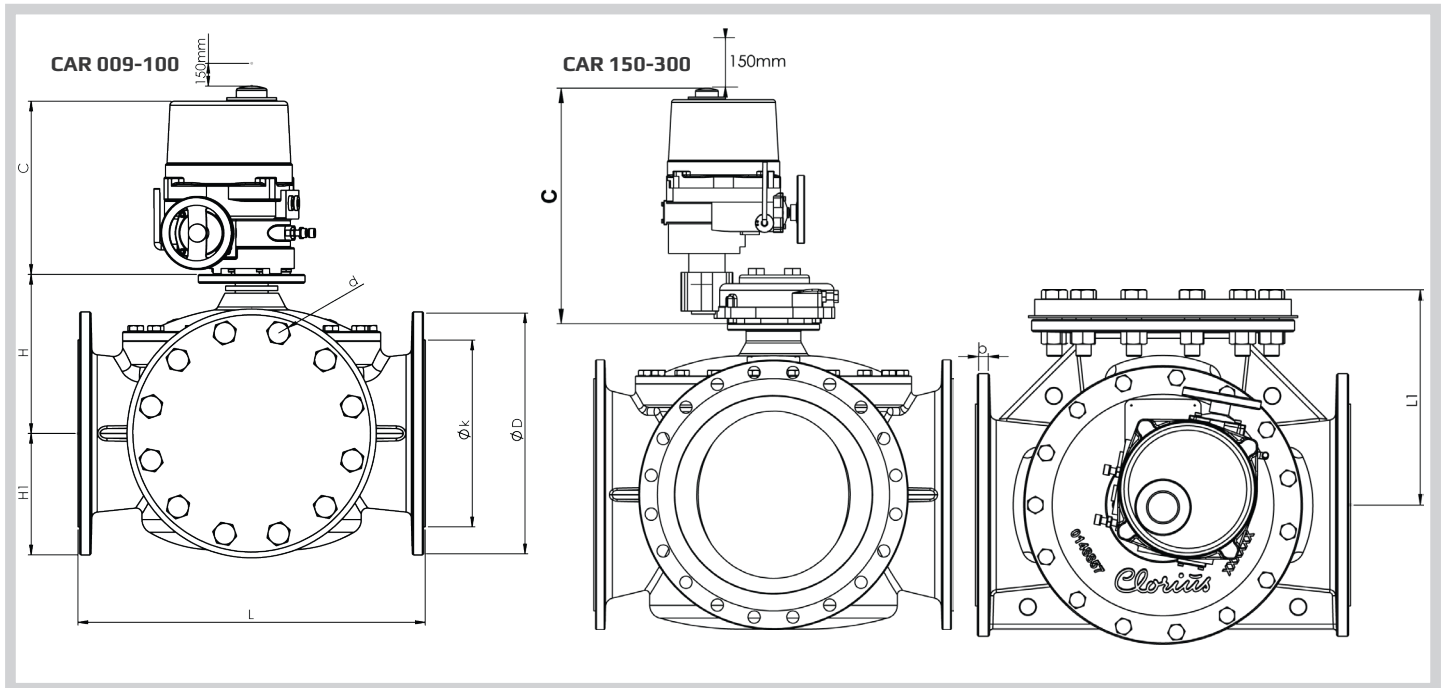

Type							EN 1092-2			ANSI Class 150			JIS B 2210 5K			JIS B 2210 10K		
	L (mm)	L1 (mm)	H (mm)	H1 (mm)	b (mm)	C (mm)	D (dia.) (mm)	k (dia.) (mm)	d mm dia. (number)	D (dia.) (mm)	k (dia.) (mm)	d mm dia. (number)	D (dia.) (mm)	k (dia.) (mm)	d mm dia. (number)	D (dia.) (mm)	k (dia.) (mm)	d mm dia. (number)
65 G2FM-T	292	175	135	90	20	273	185	145	19x(8)	180	140	19x(4)	165	130	15x(4)	175	140	19x(4)
80 G2FM-T	292	175	140	94	20	273	200	160	19x(8)	190	152	19x(4)	180	145	19x(4)	185	150	19x(8)
100 G2FM-T	350	205	158	112	17	273	220	180	19x(8)	230	190,9	19x(8)	200	165	19x(8)	210	175	19x(8)
125 G2FM-T	400	231	179	123	17	273	250	210	19x(8)	255	216	19x(8)	235	200	19x(8)	250	210	23x(8)
150 G2FM-T	438	249	196	139	20	276	285	240	23x(8)	280	241	22x(8)	265	230	19x(8)	280	240	23x(8)
200 G2FM-T	530	301	236	175	21	361	340	295	23x(12)	343	299	23x(8)	320	280	23x(8)	320	290	23x(12)
250 G2FM-T	592	333	273	205	23	361	395	350	23x(12)	407	362	26x(12)	385	345	23x(12)	400	355	25x(12)
300 G2FM-T	649	365	305	230	25.5	361	455	400	23x(12)	483	432	26x(12)	430	390	23x(12)	445	400	25x(16)
350 G2FM-T	717	395	337	255	25.5	361	490	445	23x(12)	534	477	29x(12)	480	435	25x(12)	490	445	25x(16)
400 G2FM-T	770	421	375	285	26	361	540	495	23x(16)	597	540	29x(16)	540	495	25x(16)	560	510	27x(16)
450 G2FM-T	820	446	391	310	26.5	556	595	550	23x(16)	635	578	32x(16)	605	555	25x(16)	620	565	27x(20)
500 G2FM-T	900	492	425	340	27.5	556	645	600	23x(20)	699	635	32x(20)	655	605	25x(20)	675	620	27x(20)
550 G2FM-T	900	492	425	373	27.5	556							720	665	27x(20)	745	680	33x(20)
600 G2FM-T	1000	546	470	393	31.0	556	755	705	28x(20)	813	750	35x(20)	770	715	25x(20)	795	730	33x(24)
700 G2FM-T	1106	649	519	462	34.0	556	860	810	28x(24)				875	820	27x(24)	905	840	33x(24)
800 G2FM-T	1200	702	579	507	37	556	975	920	31x(24)				995	930	33x(24)	1020	950	33x(28)

SPECIFICATIONS

Type	Flange connection DN in mm	k_{vs} -value m ³ /h	Torque Nm For inlet P*	Weight kg
60 G2FM-T	65	120	60	37
80 G2FM-T	80	154	65	41
100 G2FM-T	100	220	120	56
125 G2FM-T	125	330	200	73
150 G2FM-T	150	425	200	84
200 G2FM-T	200	1100	330	153
250 G2FM-T	250	2100	525	215
300 G2FM-T	300	2650	730	277
350 G2FM-T	350	3380	980	340
400 G2FM-T	400	3950	1370	459
450 G2FM-T	450	4480	1550	579
500 G2FM-T	500	5250	1920	744
550 G2FM-T	550	5250	1920	1090
600 G2FM-T	600	6050	2950	950
700 G2FM-T	700	7000	TBC	TBC
800 G2FM-T	800	8000	4000	2100

*Torque calculated at max inlet P for:
 DN 65 - 125 = 25 Bar
 DN 150-300 = 16 Bar
 DN 350-800 = 10 Bar

