

# Balanced 2-way Control Valve type G1FB

Nodular cast iron, PN 25, DN 25 – 65 mm

0-2.5.03-E

Page 1 of 2



## TECHNICAL DATA

### Materials:

- Valve body	Nodular cast iron EN-GJS-400-15
- Components	Stainless steel
- Nuts, bolts	24 CrMo 5/A4
- Gasket	Reinz-AFM34 Metal - Copper
- Bellow	Stainless steel W.1.1541

Nominal pressure	PN 25
Seating	Single-seated, tight closing

Flow characteristic	Quadratic
Leakage rate	$\leq 0.05\%$ of Kvs
Regulating capability	Kvs/Kvr > 25

Flanges	EN 1092-2 PN 25
---------	--------------------

Pressure balanced valve

## APPLICATIONS

The pressure balanced control valves type G1FB are designed for regulating hot water, steam and hot oil systems. Balanced valves are used in installations where the system pressure necessitates a closing force greater than available in the actuator programme for a standard single seated valve, and where the leakage rate for a double-seated valve is unacceptable.

The valves are used in conjunction with our temperature- or pressure differential regulators for controlling industrial processes, district or central heating plants or marine installations.

## DESIGN

The valve components - spindle, seat, cone and bellow - are made of stainless steel. The bellows for balancing the pressure are fitted on the valve spindle which reduces the force necessary for closing the valve, as the upstream pressure of the medium through the hollow valve spindle acts outside and the pressure after the valve acts inside the bellow system. The valve body is made of nodular cast iron EN-GJS-400-15 with flanges drilled according to EN 1092-2. The thread for the actuator connection is G1B ISO 228. The valves are single-seated. The leakage rate is less than 0.05% of the full flow (according to VDI/VDE 2174).

## FUNCTION

Without an actuator being connected, the valve is held in open position by means of a spring and the bellow system. With pressure on the spindle the valve will close. In connection with our thermostats, pneumatic or electric actuators, the valves will close at rising temperatures. For cooling circuits the valve can be used in conjunction with a reverse acting electric actuator. Alternatively a reverse acting double seated valve can be used with our self-acting thermostats. The quadratic characteristic will not cease until the flow has dropped below 4% of the full flow.

## FEATURES

- Simple design secures reliable controls.
- Location of the pack box in the actuator makes the valve service friendly
- Reliable and secure due to internal parts of stainless steel
- Low leakage rate reduces the risk of overheating

## PRESSURE/TEMPERATURE DIAGRAM

According to DIN 2401

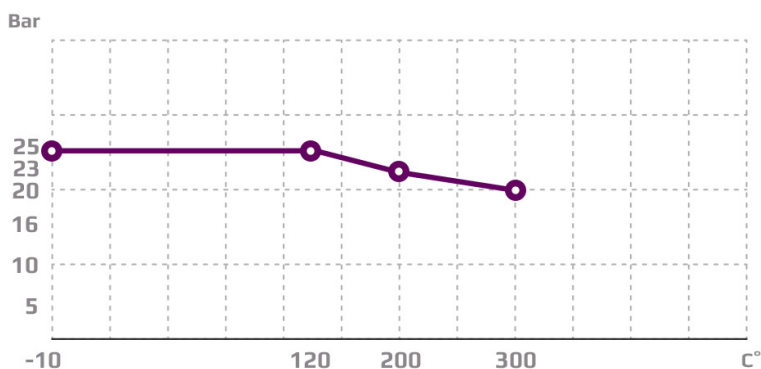

Subject to change without notice.

## MOUNTING

The valve can be installed with vertical as well as horizontal spindles. For valve temperatures of max. 170 °C, the thermostat/ actuator can be fitted below or above the valve. For valve mounted with thermostats in media temperatures above 170 °C, a cooling unit has to be applied with connection downwards (please refer to data sheet for thermostat accessories). For electric actuators a high temperature adaptor must be used (please refer to data sheets for the electric actuators).



## DIMENSION SKETCH

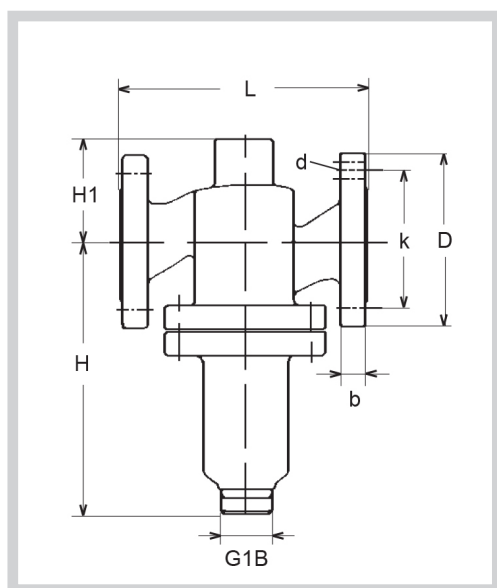

Type	L mm	H mm	H1 mm	D (dia.) mm	b mm	k (dia.) mm	d mm dia. (number)
25 H1FB	160	180	70	115	16	85	14x(4)
32 H1FB	180	195	75	140	18	100	18x(4)
40 H1FB	200	205	85	150	19	110	18x(4)
50 H1FB	230	225	95	165	19	125	18x(4)
65 H1FB	290	260	110	185	19	145	18x(8)

## SPECIFICATIONS

Type	Flange connection DN in mm	Opening (mm)	$k_{vs}$ -value $m^3/h$	Lifting height (mm)	Weight (kg)
25 G1FB	25	25	7.5	7	6
32 G1FB	32	32	12.5	8	9
40 G1FB	40	40	20	9	13
50 G1FB	50	50	30	10	16
65 G1FB	65	65	50	13	23