

Characteristics

- Nominal pressure
DN 200-300 mm:
PN 16, max. 100°C (option 250°C)
DN 350-600 mm:
PN 10, max. 100°C (option 250°C)
- Slide in Nodular cast iron

Applications

Control valve type G3FM-TR is a three-way control valve with a slide for quarter turn operation designed for regulating of fresh water, lubricating oil and other liquid media.

The valves are designed for use in conjunction with industrial processes, district heating and marine installations with large water or lubricating oil quantities:

- Engine Jacket Cooling Water System
- Lubricating Oil Cooling
- Central Cooling Water System, etc.

The valves are designed for use in conjunction with valve motor type RCEL with handle for manual operation or for use in conjunction with a pneumatic actuator.

Function

The slide is firmly connected with the motor spindle. When the slide is in the one extreme position by turning the spindle, connection A-AB is kept fully open and connection B-AB is fully closed. In the other extreme position connection A-AB is fully closed and connection B-AB is fully open. In the intermediate positions the opening degrees change proportionally.

The valve has a small tolerance between body and slide. To minimize the leakage an O-ring is mounted in a groove on the slide.

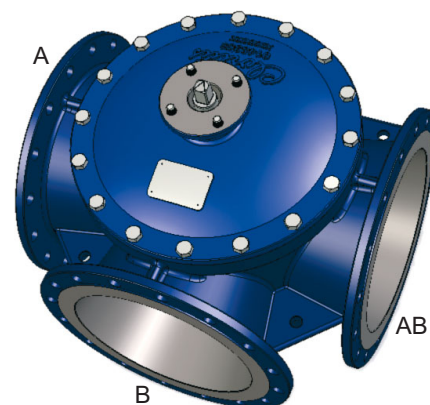

Technical data

Materials:
- Valve body, slide Nodular cast iron
EN-GJS-400-15
- O-ring NBR 70A

Nominal pressure:
- DN 200-300 PN 16
- DN 350-600 PN 10

Valve characteristic Almost linear

Leakage Max. 0.5%

Temperature range Max. 100°C (option 250°C)

Mounting See page 2

Flanges EN 1092-2
PN 10/16

Counter flanges (suggested) DIN 2632 – PN 10
DIN 2633 – PN 16

Max. pressure Δp_L , against which the control can close:
- DN 200-300 16 bar
- DN 350-600 10 bar

Dimensioning

For sizing of control valves the following equation can be used:

$$k_{vs} = \frac{G(m^3/h)}{\sqrt{\Delta p(\text{bar})}}$$

$$\Delta p(\text{bar}) = \left(\frac{G(m^3/h)}{k_{vs}} \right)^2$$

Design

The valve body and the valve slide are made of nodular cast iron.

The valve flanges are drilled according to EN 1092-2.

Quality assurance

All valves are manufactured under an ISO 9001 certification, and are pressure and leakage tested before shipment.

For marine applications the valves can be supplied with relevant test certificates from recognized classification societies.

Specifications

Type	Flange connection DN in mm	k_{vs} -value ¹⁾ Mixing valve m ³ /h	k_{vs} -value ¹⁾ Diverting valve m ³ /h	Torque Nm	Weight kg
200 G3FM-TR	200	800	1100	330	114
250 G3FM-TR	250	1500	2100	450	159
300 G3FM-TR	300	2000	2650	700	207
350 G3FM-TR	350	2530	3380	780	278
400 G3FM-TR	400	3050	3950	880	346
450 G3FM-TR	450	3680	4480	1250	433
500 G3FM-TR	500	4150	5250	1450	563
600 G3FM-TR	600	4800	6050	1750	816

¹⁾ k_{vs} -value for port A and B 50% open.

Port numbering



Subject to change without notice.

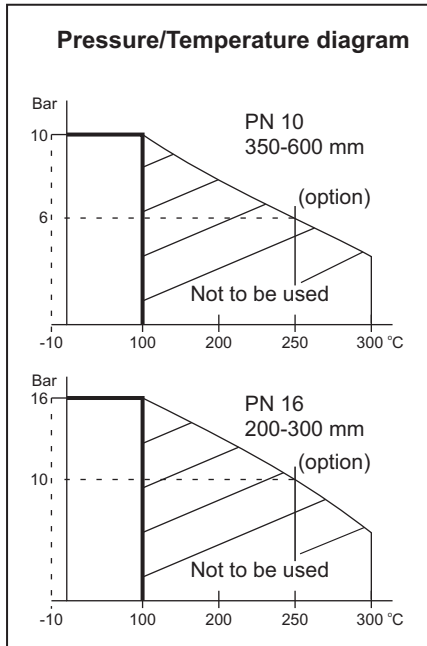

Dimension sketch

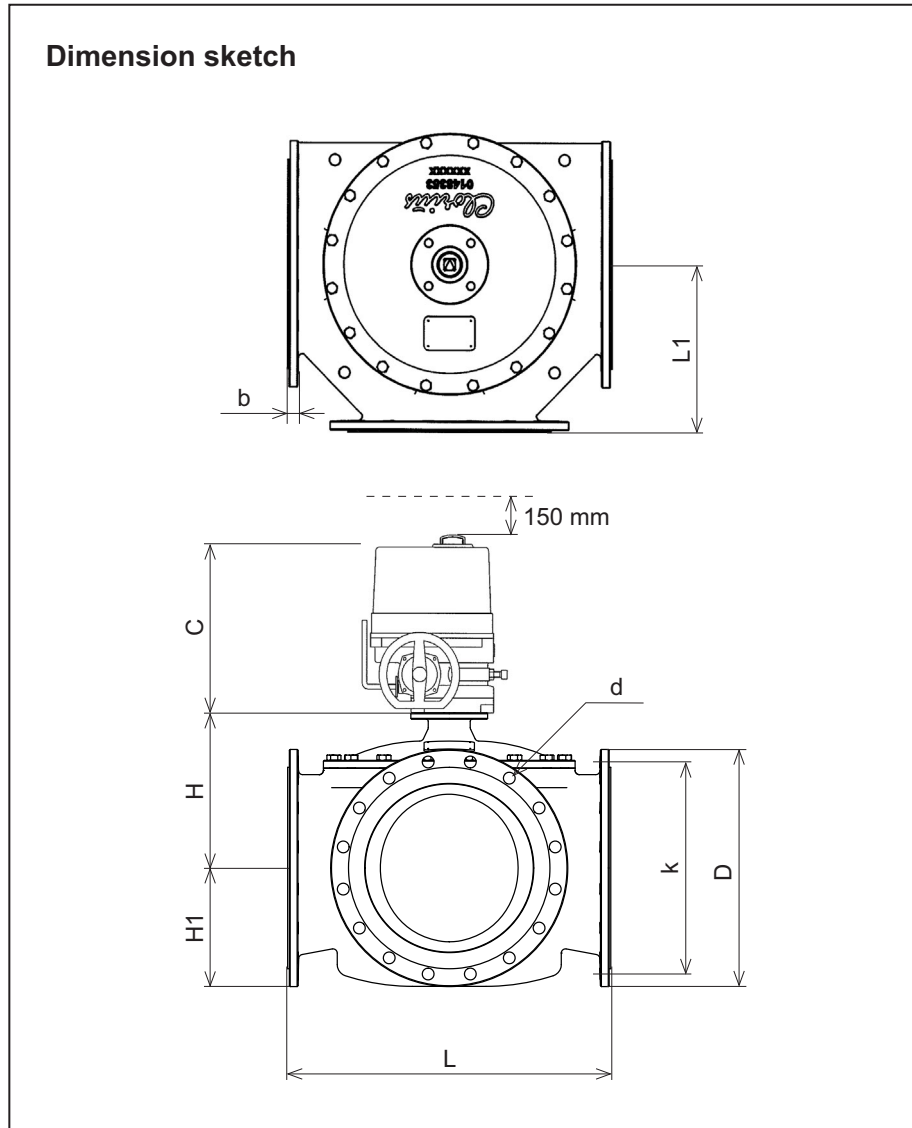

Definition of k_{VS} -value

The k_{VS} -value is identical to the IEC flow coefficient k_V and defined as the water flow rate in m^3/h through the fully open valve by a constant differential pressure, Δp_V , of 1 bar.

Mounting

The valve connections are marked A, B and AB. The slide is operating between A and B.

Check slide position before installation in the pipe. The slide position is marked on the top of the shaft.

The valves can be installed with vertical as well as horizontal spindles. The valves must be mounted in a way that the valve actuator will be exposed to a minimum of moisture and unnecessary vibrations.

Valves can also be supplied in AB-Left configuration (data sheet 2.6.03).

Strainer

It is recommended to use a strainer in front of the control valve if the liquid contains suspended particles.

Type	L mm	L1 mm	H mm	H1 mm	b mm	C mm	D (dia.) mm	k (dia.) mm	d mm dia. (number)
200 G3FM-TR	530	270	236	175	21	361	340	295	23 x (12)
250 G3FM-TR	592	300	273	205	23	361	400	355	28 x (12)
300 G3FM-TR	649	330	305	230	25.5	361	455	410	28 x (12)
350 G3FM-TR	717	360	337	255	25.5	361	505	460	23 x (16)
400 G3FM-TR	770	385	375	285	26	361	565	515	28 x (16)
450 G3FM-TR	820	410	391	310	26.5	556	615	565	28 x (20)
500 G3FM-TR	900	455	425	340	27.5	556	670	620	28 x (20)
600 G3FM-TR	1000	505	470	393	31.0	556	780	725	31 x (20)

Subject to change without notice.