

# Instructions

## Temperature Controller Type ER 2290



# Controller Type ER 2290

## Contents

|   | Page |
|---|------|
| 1. Application, function.....                       | 3    |
| 2. Installation.....                                | 3    |
| 3. Electrical connections.....                      | 3    |
| 4. Dimensions, setting and commissioning.....       | 4    |
| 5. Control behaviour of the PI step controller..... | 6    |
| 6. Relation $X_p$ , $K_p$ , $T_p$ , saturation..... | 7    |
| 7. Troubleshooting.....                             | 7    |
| 8. Sensor characteristic (Pt 100).....              | 7    |
| 9. Electrical diagram.....                          | 8    |

## Technical Data

|   |  |
|---|--|
| Mains connection                            | 230 V, +10%, -15%, 50...60 Hz  |
| Mains fusing                                | 1 A, internally or externally  |
| Fuse output relays                          | 3,15 A (internally)  |
| Power input without valve motor             | 5 VA   |
| Protection class                            | terminals IP00, housing IP42   |
| Permissible ambient temperature             | 0 - 50°C   |
| Sensor                                      | Pt 100 (100 Ohm at 0°C).<br>3-wire connection. No line balance required.                       |
| Output signal                               | 230 V, 50...60 Hz<br>I max. = 0,8 A<br>pulses for valve motor                                  |
| Responsiveness                              | $\pm 0,2 \dots \pm 0,6\%$ (setpoint range),<br>internally adjusted to $\pm 0,4\%$              |
| P-range $X_p$ as pulse proportioning factor | 1 - 10 = 45 - 6 s/% at saturation = 18%<br>1 - 10 = 8 - 1,2 s/% at saturation = 4%             |
| Reset time $T_n$                            | 1 - 10 = 1 - 7 min or<br>1 - 10 = 6 - 12 min<br>(change-over possible through internal switch) |
| <b>Indicator</b>                            |  |
| Deviation between setpoint and actual value |  |
| internally                                  | 0 ... $\pm 30^\circ\text{C}$   |
| externally                                  | 0 ... +20% (500 mV/%)  |
| Actual value externally                     | 0 - 10 V   |
| Weight                                      | 0,8 kg   |

Technical changes reserved!

## 1. Application, Function

Unit for constant temperature control.

Its field of application is primarily in industrial plants and marine installations.

The controller is suitable for all heat and cooling control systems.

Data acquisition is effected via sensors of varying design for gaseous and liquid media.

The measured value of the controlled variable is compared with the setpoint and adjusted via a valve motor with PI-behaviour.

The unit permits direct reading of the actual temperature value, and it is inherently safe from the measuring circuit, i.e. the controller will give a closing command in case of failure of the measuring sensor ( $R = \infty$ ).

The closing command will also be given in case of a short circuit in the sensor ( $R = 0$ ).

## 2. Installation

### a) ER 2290

The controller is suited for front panel installation only. Insert unit from front into the cut-out of the control panel (92 x 92 mm) and fasten by means of 2 clamps supplied with the unit (see also page 4).

### b) Sensor

Adhere to the operating instructions or the worksheet of the sensor being used.

If the sensor is to be installed in a tube, attention should be paid that the sensor shaft is fully immersed in the medium to be measured and directly exposed to the temperature. Screw in the sensor using an open-mouth wrench only.

Never attempt screwing by rotating the casing.

Pay attention to short response time and short dead time.

### c) Control valve and valve motor

Observe the marks and symbols on the valve body when installing the equipment.

Refer also to the operating instructions and to the worksheet for the equipment being used.

Install as close to the consumer as possible.

### d) Indicators (external)

According to operating instructions or worksheets of the indicators being used.

### e) Setpoint variator (external)

According to operating instructions or worksheets of the variator being used.

## 3. Electrical Connections (refer to page 8)

a) The terminals with terminal connection diagram are located at the rear side of the unit.

b) Adhere to the local regulations for installation. As electric noise is an increasing problem we recommend the use of shielded cables for the measuring lines – unless electric noise is out of the question.

### c) Power Supply

230 Volts, 50 to 60 cycles; +10%...-15%

Connect unit to earth or neutral conductor according to the regulations of the local power plant.

|       |             |    |  |
|-------|-------------|----|--|
| Earth | to terminal | ⊥  |  |
| N     | to terminal | 1  |  |
| Phase | to terminal | 2  | for controller<br>(over external fuse) |
| Phase | to terminal | 62 | for valve motor                        |

### d) Sensor

Three-wire connection; no line balance required.

Connect to terminals 28, 29, 31; connect terminals 29 and 31 jointly to the sensor.

### e) Valve motor

Connect terminals of motor drive directly to terminals 12 and 14 of the controller. Connect motor drive to earth or neutral conductor according to the regulations of the local power plant.

If it is too cold, the voltage is applied to terminal 12.

If it is too warm, the voltage is on terminal 14.

In case of wrong direction of operation, interchange the connections between controller and motor drive either at terminals 12, 14 of the controller or at terminals of the motor drive. Please also see the documentation for the control valve involved.

### f) Indicators (external)

Actual value indicator to be connected to terminals 50 and 51. Connect indicator for deviation between setpoint and actual value to terminals 50 and 71.

### g) Setpoint Variator (external – see page 4 fig 6)

Connect to terminals 44, 45, 50, and slider to 44. Internal setpoint potentiometer must be disconnected.

### h) Signal Output

Potential-free changeover contact to terminals 58, 59, 60. Term. 59 is the joint connection. The output works according to the static current principle, i.e. in case of overload the relay becomes deenergized.

# 4. Dimensions, Setting and Commissioning

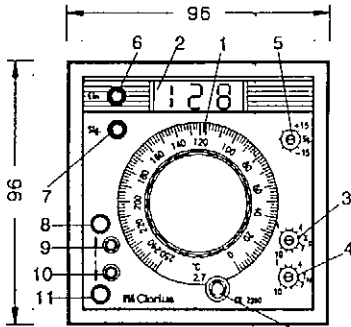

Fig. 1: Front view 1a

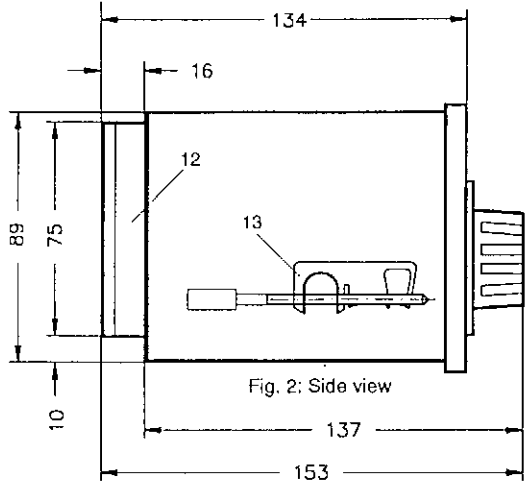

Fig. 2: Side view

printed card ER 2290-L Fuse behind output relays printed card ER 2290-R

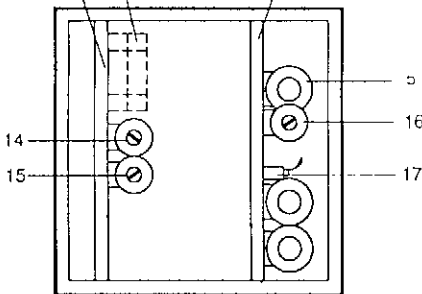

Fig. 3: Interior view behind the front pane

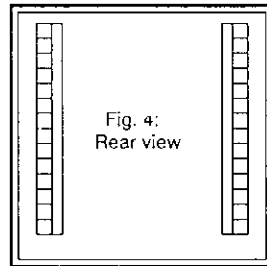

Fig. 4: Rear view

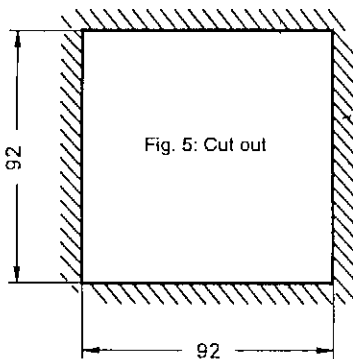

Fig. 5: Cut out

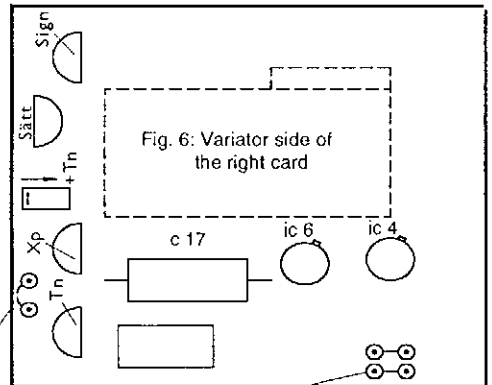

Fig. 6: Variator side of the right card

when bridged:  
3-point behaviour

if an external setpoint potentiometer is connected, open both bridges to disconnect the internal setpoint potentiometer

a) Operating elements









- 1 (W) Setpoint potentiometer with stop (1 a)
- 2 3-digit digital display
- 3(Tp) Potentiometer for setting the pulse proportioning factor (Kp)
- 4(Tn) Potentiometer for setting the reset time
- 5 Potentiometer for setting of signal output
- 6 LED "Mains ON"
- 7 LED signal output
- 8 LED OPEN <sup>1)</sup>
- 9 Key for OPEN <sup>1)</sup>
- 10 Key for CLOSED <sup>1)</sup>
- 11 LED CLOSED <sup>1)</sup>, pulsing
- 12 Terminal strip
- 13 Clamps for fastening
- 14 Potentiometer for setting of the switching difference of the signal unit
  - left stop : 0,5 %
  - right stop : 3 %
  - condition on delivery : 0,5% (left stop)
- 15 Potentiometer for setting the sensitivity (switching gap between OPEN and CLOSE command)
- 16 Potentiometer for setting the saturation, refer to page 7
  - left stop : 4 %
  - right stop : 18 %
  - condition on delivery : 18 % (right stop)
- 17 sliding switch to lengthen the reset time Tn (refer to fig 3)
 

|                          |                   |
|--------------------------|-------------------|
|                          | <u>Reset time</u> |
| <input type="checkbox"/> | 1 - 7 min.        |
| <input type="checkbox"/> | 6 - 12 min.       |

b) Indicator (refer to fig 1, pos 2)

3-digit digital display for actual temperature.

c) Manual control (refer to fig. 1, pos. 9, 10)

- none of the keys are pressed: **9** **10**  
   automatic operation  
- press the key pos. 9:  
   valve opens <sup>1)</sup>  
- press the key pos. 10:  
   valve closes <sup>1)</sup>  
- press both keys:  
   valve motor stops  

as long as the key is pressed or until the end position is reached.

<sup>1)</sup> Valid for heating systems (reverse function in cooling systems).

d) Setting range (refer to fig 1, pos. 1). The setting range appears from the setpoint potentiometer.

e) Signal unit (refer to fig 1, pos 5 & fig 3, pos 14)  
 The set signal value  $W_s$  ( $W_s = W \pm \dots 15\%$ ), adjustable by potentiometer (5), depends upon the adjusted setpoint value  $W$ .

By exceeding ( $W_s = W + 0 \dots 15\%$ ), or falling short ( $W_s = W - 0 \dots 15\%$ ) of the signal value  $W_s$ ; contact closure 58 and 59, LED is lit.

f) Three point behaviour (refer to fig 6)

The three point behaviour is produced by short circuiting the bridge 3P, whereby the controller supplies only 3 switch conditions (no led pulses!).

Actual value < setpoint:

contact closure at terminals 62, 12

Actual value > setpoint:

contact closure at terminals 62, 14

Actual value = setpoint:

contact 62, 12 and 62, 14 are open.

g) Response sensitivity E (refer to fig 3, pos 15):

Switching gap between open and closed commands:

 left stop 1: smallest sensitivity = largest switching gap approx.  $\pm 0,6\%$

 right stop 10: greatest sensitivity = smallest switching gap approx.  $\pm 0,2\%$

If the valve motor continuously oscillates between open and closed position, the sensitivity E is reduced by turning to the left until the oscillations cease.

h) Adjustment of the controller to the controlled system

Set P-range  $X_p$  to the smallest value.

Set reset time to the largest value (condition on delivery).

Put the control system into operation. Wait until setpoint is reached.

Reduce P-range  $X_p$  step by step and observe the control behaviour at small setpoint changes.

If the control starts to oscillate, the P-range  $X_p$  is increased until the desired stability is reached. Afterwards the reset time  $T_n$  is reduced step by step until the control system starts to oscillate again.

The reset time must now be increased until the control system has the required stability.

### 5. Control behav. of the PI step controller

The control behaviour of the 3 point step controller must be viewed basically in connection with the actuated motor driven setting element, since the PI behaviour of controller/valve motor is produced only by the integrating behaviour of the setting motor (addition of the individual current pulses to the total pulse proportioning factor).

The behaviour of the controller should be explained taking as example a change in the controlled variable  $x$  occurring abruptly.

The controlled variable should experience an abrupt change of 10% of the setpoint range. This change of  $x$  results directly in a voltage pulse at the setting element output. The length of this pulse depends upon the set pulse proportioning factor  $T_p$  (adjusted with  $X_p$ -potentiometer, refer to fig. 3, pos. 3 and page 7). At a set pulse proport. factor of  $T_p = 2 \text{ s}/\%$ , for example, this pulse has a length of  $(2 \text{ s}/\%) \times 10\% = 20 \text{ s}$ , i.e. the valve motor runs for 20 s.

This pulse represents the P component of the PI controller. The I component of the PI controller follows from the P-component, as long as the control deviation continues unchanged.

The I component is represented by several voltage pulses. The pulse interval ratio of these pulses is adjusted by the reset time  $T_n$ .

$T_n$  establishes the time within which the sum of the integration pulses achieves the same travel as already done by the first pulse (P-component). In our example, a reset time of  $T_n = 3 \text{ min}$  should be set. Then firstly at a control deviation of 10% of the control range (setpoint range) a pulse of 20 s duration takes place. After that the valve motor is actuated with pulses, the pulse interval ratio of which is such that every 3 min so many pulses have occurred that the sum of the switchon times is the same as the switchon time of the first pulse lasting 30 s.

If the control deviation continues to exist, further integration pulses follow as described above.

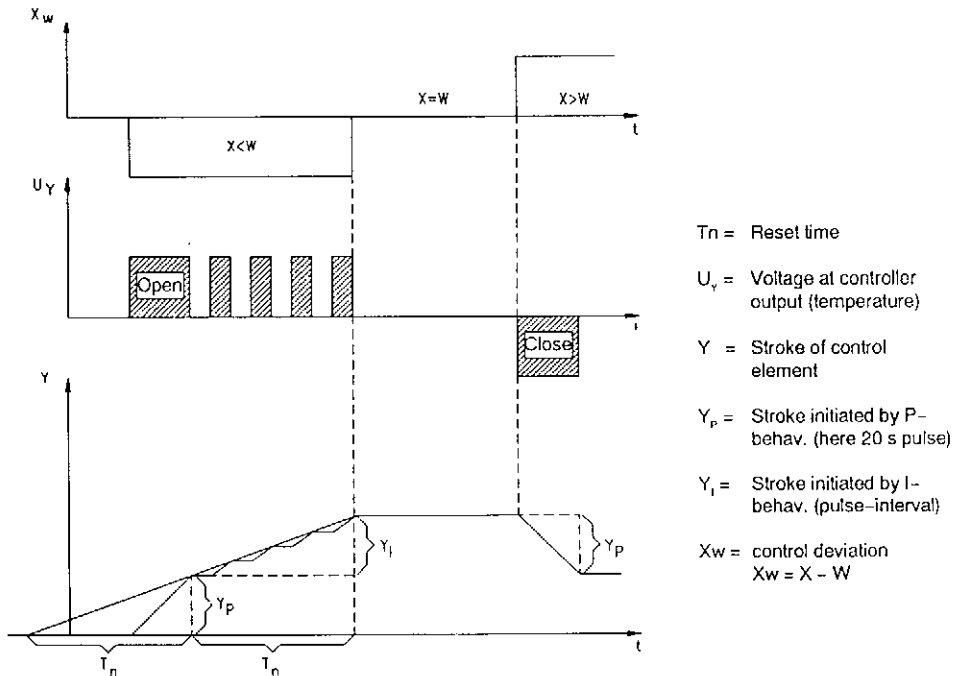

Fig. 7: Impulse behaviour of the PI controller

If the control deviation disappears, no further pulses follow, i.e. the motor driven setting element retains its position, which it has reached by the previous pulses. The diagram page 6 shows an example for such a control process.

**6. The relation Xp, Kp, Tp and saturation:**

Kp: gain

Xp: P-range (refer to fig.3, pos. 3)

Tp: pulse proportioning factor (refer to fig.3, pos. 3) saturation (refer to fig.3, pos 16) indicates a max. value of Xw, then continuous impuls follow.

The controlled variable can't be standardized because of the missing fixed feedback of the valve (valve motor). An auxiliary variable was adopted, which was defined as pulse proportioning factor Tp

$$Tp = 1/Xp - Kp$$

The pulse proport. factor is inverse proportional to the P-range and is equivalent to the gain Kp.

For an optimal Xp the pulse proportioning factor Tp can be adjusted as follows:

$$Tp = 1/Xp \times Y100/Yy$$

↙ valve stroke (mm)

↘ setting speed of the valve (mm/s)

**7. Troubleshooting**

a) Is the specified mains voltage being applied to terminals No. 1 and 2? LED (6) indicates "Mains ON".

b) Check sensor and its connection to the controller for interruptions and shortcircuiting. (Test sensor with a resistance measuring bridge – see the sensor characteristic).  
If the sensor is interrupted or short-circuited, the controller switches to "Close" in either case. If the sensor is defective, the controller may be checked by connecting an equivalent resistance. The zeropoint of the controller must be obtained when setpoint and actual value are identical.

c) Is the valve motor alright?

Check in accordance with the corresponding operating instructions for proper electrical and mechanical functioning.

**Important:** Is the seat leakage of the control valve too large?

Depending on the size of the leak a leaking control valve may cause temperature deviations from the setpoint and thus affect the controller result. Is the dirt trap alright?

d) If you find the controller itself to be the cause for the trouble, a service engineer should be called or a replacement for the controller should be used.

The setting range for Tp is dependent on the set saturation (refer to page 4, fig. 3, pos. 16).

| Set saturat. | Scale of Xp (Kp)  | Pulse proport. factor Tp |
|--------------|-------------------|--------------------------|
| 18 %         | 1 (10) ... 10 (1) | 8 s/% Xw...1,2 s/% Xw    |
| 4 %          | 1 (10) ... 10 (1) | 45 s/% Xw....6 s/% Xw    |

**8. Sensor characteristic (Pt 100):**

| °C   | Ohm    | Ohm/°C | °C   | Ohm    | Ohm/°C |
|------|--------|--------|------|--------|--------|
| -100 | 60,20  | 0,405  | +100 | 138,05 | 0,378  |
| 90   | 64,25  | 0,403  | 110  | 142,28 | 0,378  |
| 80   | 68,28  | 0,401  | 120  | 146,06 | 0,376  |
| 70   | 72,29  | 0,399  | 130  | 148,82 | 0,375  |
| 60   | 76,28  | 0,397  | 140  | 153,57 | 0,375  |
| 50   | 80,25  | 0,396  | 150  | 157,32 | 0,373  |
| 40   | 84,21  | 0,396  | 160  | 161,05 | 0,371  |
| 30   | 88,17  | 0,396  | 170  | 164,76 | 0,371  |
| 20   | 92,13  | 0,394  | 180  | 168,47 | 0,369  |
| 10   | 96,07  | 0,393  | 190  | 172,16 | 0,368  |
| 0    | 100,00 | 0,390  | +200 | 175,51 | 0,367  |
| 10   | 103,90 | 0,389  | 210  | 179,51 | 0,366  |
| 20   | 107,79 | 0,388  | 220  | 183,17 | 0,365  |
| 30   | 111,67 | 0,387  | 230  | 186,82 | 0,364  |
| 40   | 115,54 | 0,386  | 240  | 190,46 | 0,362  |
| 50   | 119,40 | 0,384  | 250  | 194,08 | 0,362  |
| 60   | 123,24 | 0,383  | 260  | 197,70 | 0,360  |
| 70   | 127,07 | 0,382  | 270  | 201,30 | 0,358  |
| 80   | 130,89 | 0,381  | 280  | 204,88 | 0,358  |
| 90   | 134,70 | 0,380  | 290  | 208,46 | 0,357  |

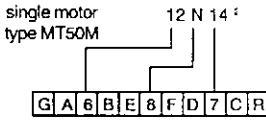
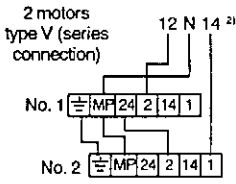
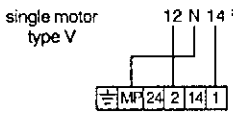
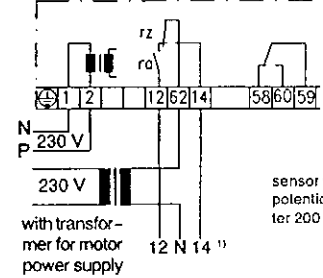
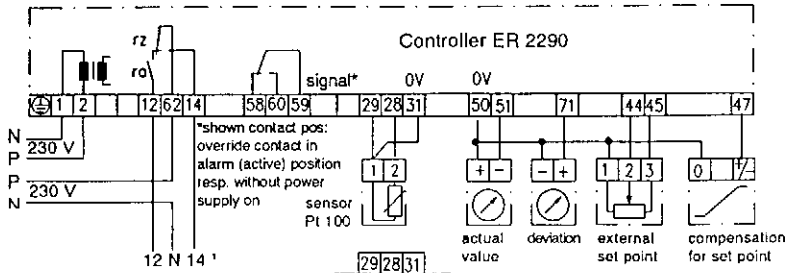

if these equipments are not connected the corresponding terminals remain free

**Important:** when connecting a measuring voltage (0 till -10 V) the modul must be removed

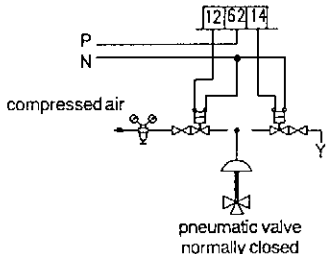
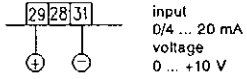
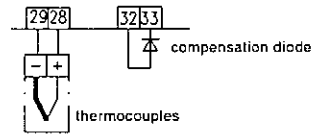
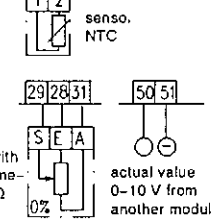

<sup>1)</sup> System for: heating cooling  
 voltage on 12 for: opening closing  
 voltage on 14 for: closing opening

<sup>2)</sup> Valid for heating systems.  
 Interchange the connections between terminal 12 and 14 for cooling systems.

### Electrical Connections



Clorius Controls A/S  
 Tempovej 27 · DK-2750 Ballerup · Denmark  
 Tel.: +45 77 32 31 30 · Fax: +45 77 32 31 31  
 E-mail: mail@cloriuscontrols.com  
 Web: www.cloriuscontrols.com