

Temperature and Pressure Controls Applications

Clorius
Controls A/S

- ensures reliable
control of heating, cooling
and ventilation systems.

Clorius Controls solves the task of temperature control

Any task where a media is heated or cooled to a certain temperature, Clorius Controls has the solution.

Examples of medias to be heated / cooled:

- Fresh water**
- Hot water**
- Lubricating oil**
- Fuel oil**
- Air**
- Asphalt**

Examples of valve media:

- Fresh water**
- Sea water**
- Hot water**
- Lubricating oil**
- Steam**
- Heat transfer oil**

Limits for the valve media:

- Temperature up to **350°C**
- Pressure up to **40 bar**
- k_{VS} up to **8000 m³/h**

The Clorius Controls Scope of Supply

Valves:

2-way valves

Sizes DN 15/4 - DN 600
Single / double seated

3-way valves

Sizes DN 15 - DN 800

Body material:	gun metal cast iron nodular cast iron cast steel
Spindle:	stainless steel
Cone and seat:	stainless steel gun metal

Control equipment:

Self-acting temperature control
consisting of

thermostat
sensor
capillary tube

Electronic temperature control
consisting of

valve motor
PI(D) controller
sensor

Pneumatic temperature control
consisting of

actuator
positioner
PI controller
sensor

Pressure control consisting of

pressure reducing valve

Certificates

Work certificates
Test certificates from a
Classification Society

Instructions

Installation guidelines
Maintenance instructions
Operation instructions

Application examples

Main engine and auxiliary engine:

- Jacket cooling water system
- Piston cooling
- Nozzle cooling
- Load- and scavenging air cooling
- Lubricating oil cooling

Oil preheating:

- Fuel oil and diesel oil
in storing-, settling-, and service tanks
- Preheating prior to separation and injection

Heat Exchangers:

- Water heaters for radiator plant
- Water heaters for domestic water
- Evaporators (production of freshwater)

Tank Heating:

- Bilge water tank
- Cargo tank
- Sludge tank
- FO drain tank
- FO overflow tank
- Asphalt tank

Air Conditioning Plant:

- Preheating of air
- Reheating of air
- Cooling of air

Solutions are depending on the actual method required:

2-way valve with self-acting thermostat or with actuator, controller and sensor.

3-way valve (mixing or diverting) with self-acting thermostat or with actuator, controller and sensor.

Actuators can be electrical or pneumatic or electric/pneumatic.

Self-acting pressure reduction.

Hydraulic and electric/hydraulic actuators are optional solutions.

Communication with central control systems (RS 485 for controller type ER 2000).

Solutions

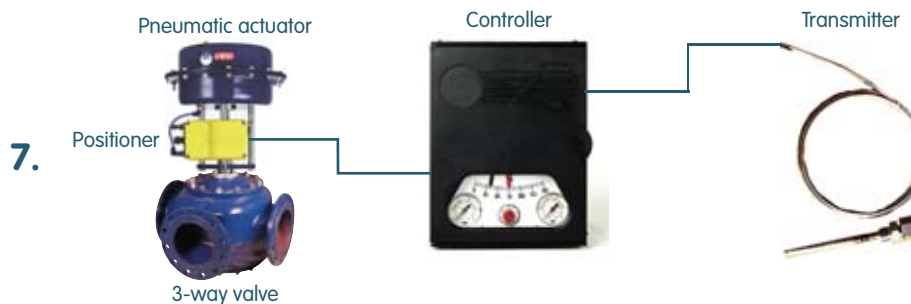
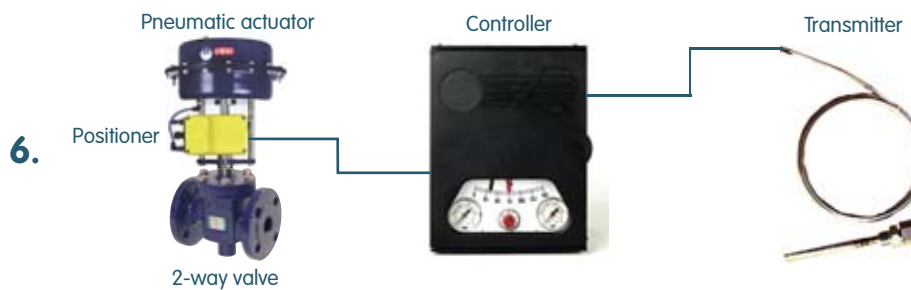

Application in principle

Engine jacket cooling water system

Solution 2, 4 and 7 (ref. page 4)

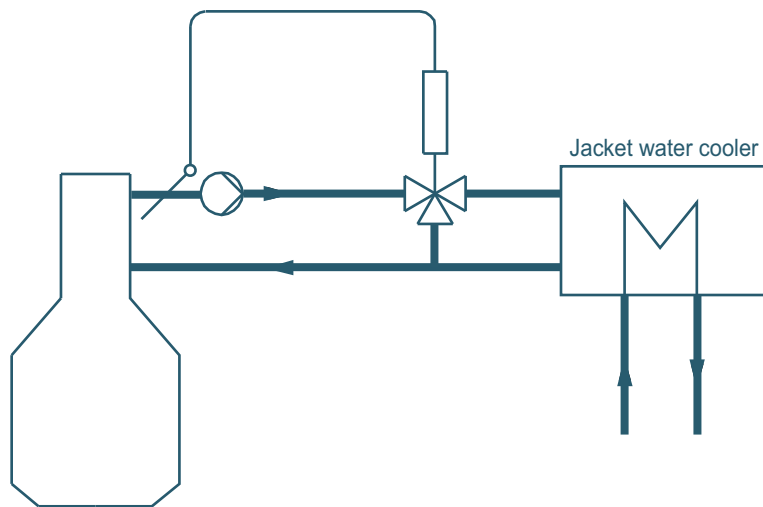

Solution 5 (ref. page 4)

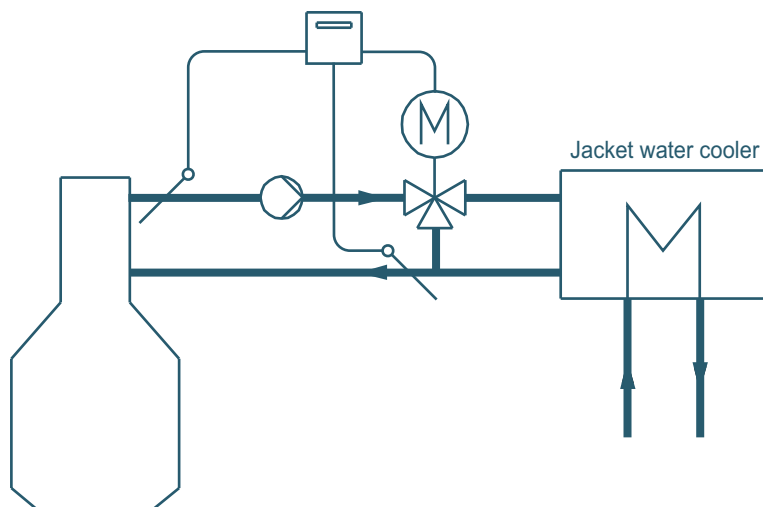

Lubricating oil cooling

Solution 2, 4 and 7 (ref. page 4)

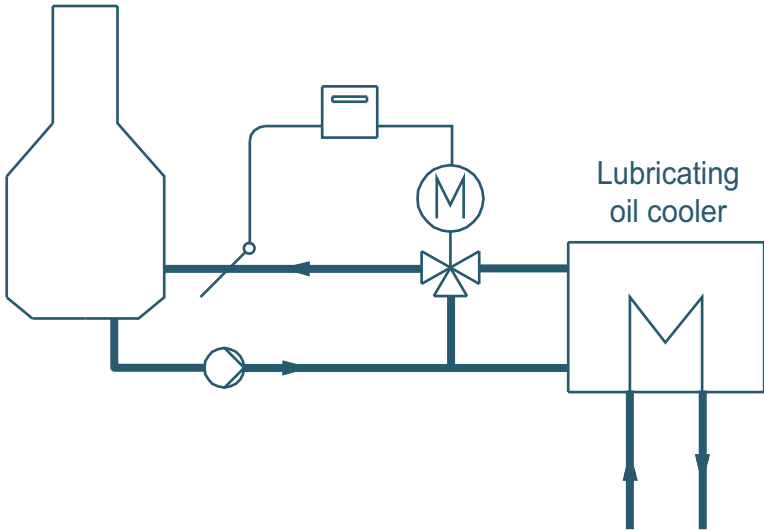

Central cooling water system

Solution 2, 4 and 7 (ref. page 4)

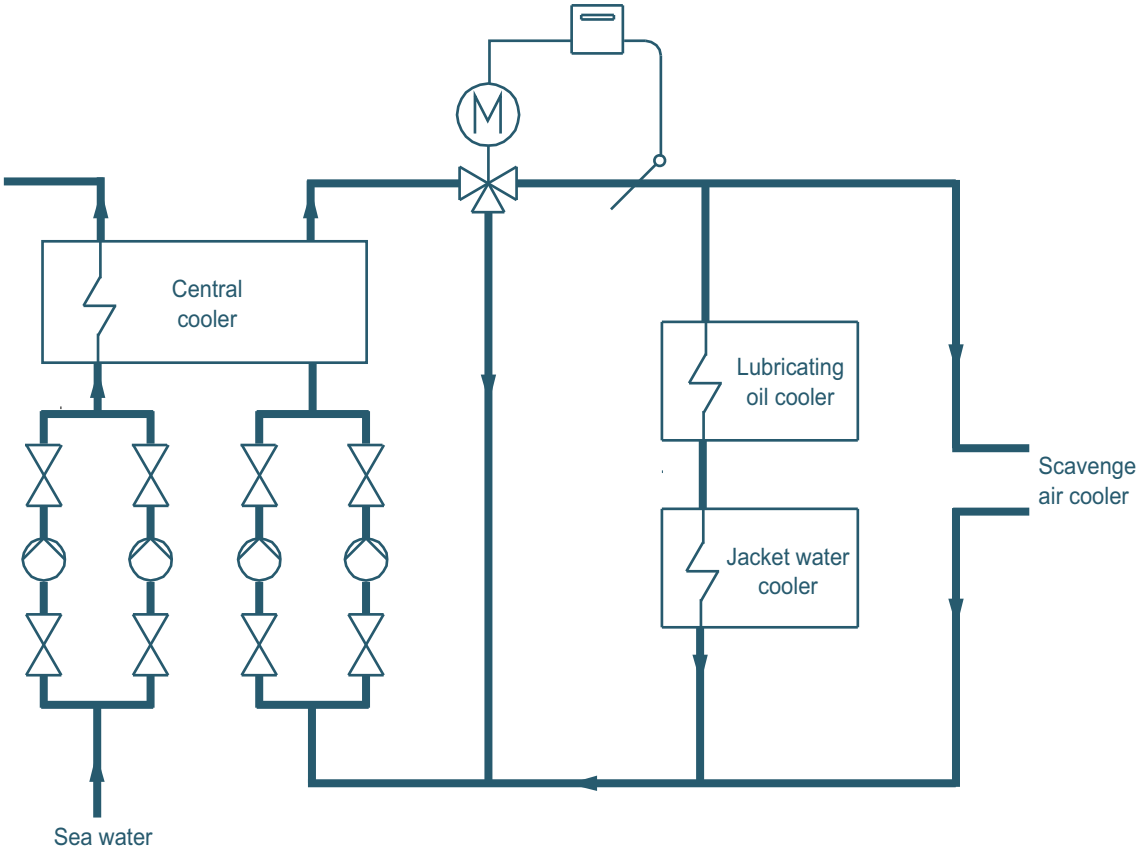

Oil preheating

Solution 1, 3 and 6 (ref. page 4)

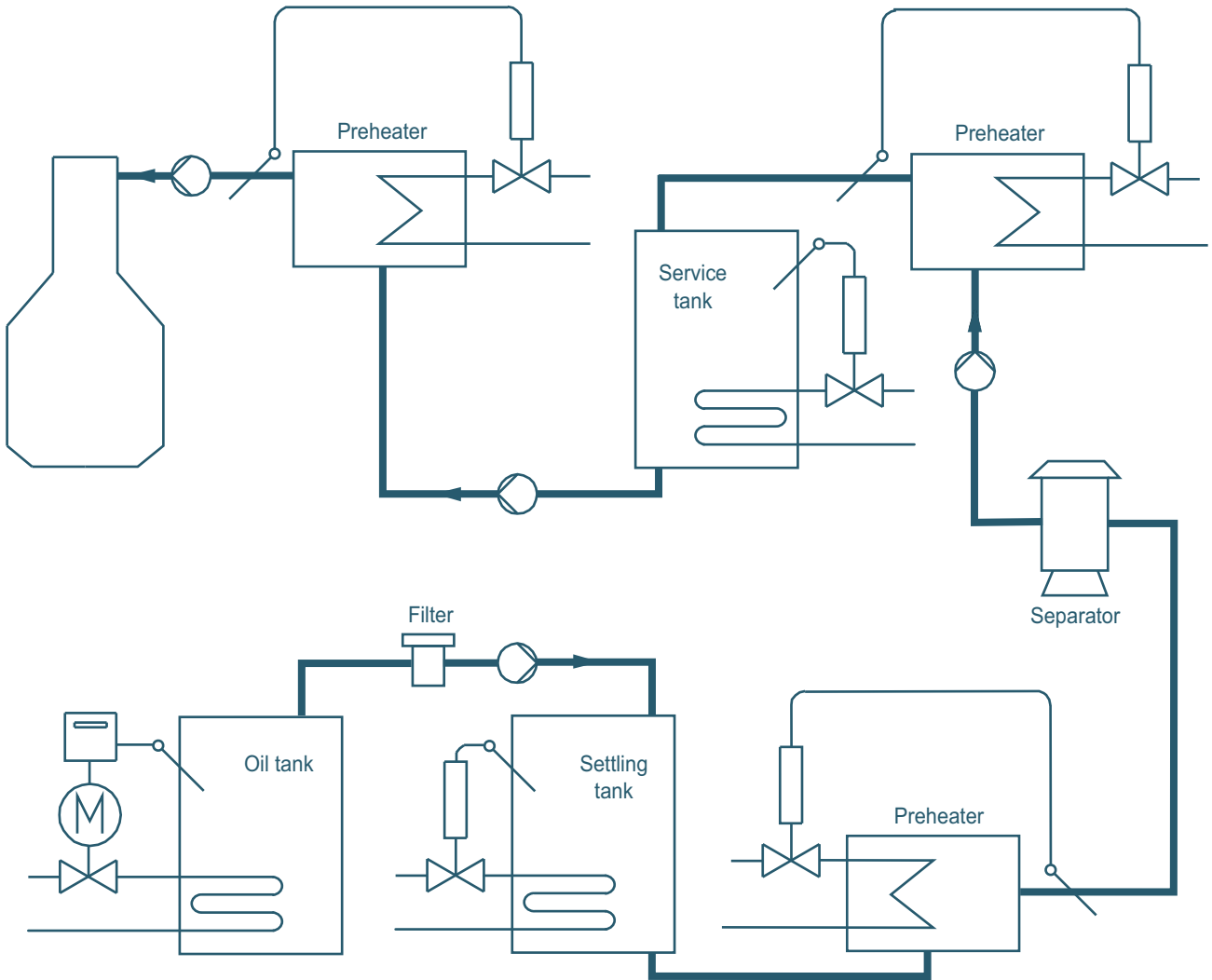

Hot water tank heating

Solution 1, 3 and 6 (ref. page 4)

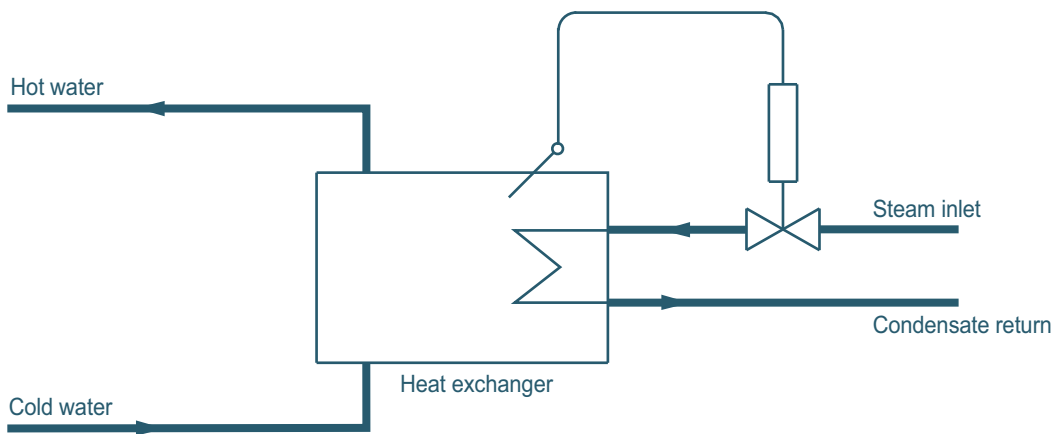

(Principle only)

Air conditioning plant

Solution 1 (ref. page 4)

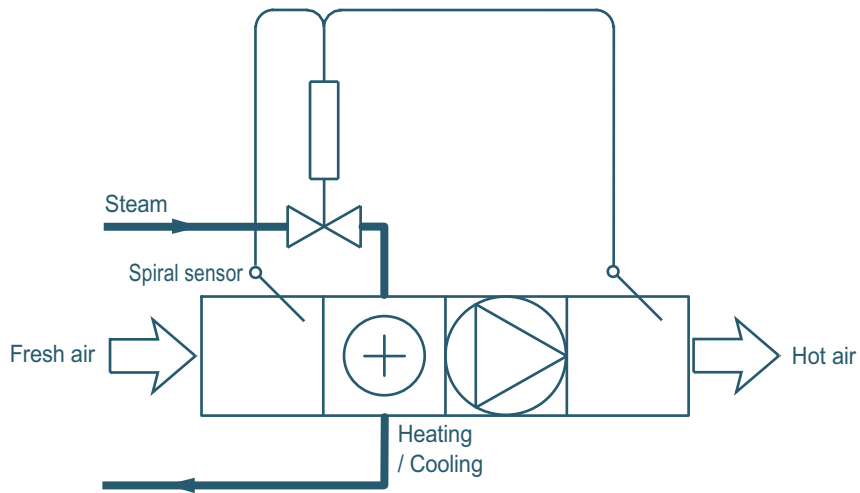

Solution 2, 4 and 7 (ref. page 4)

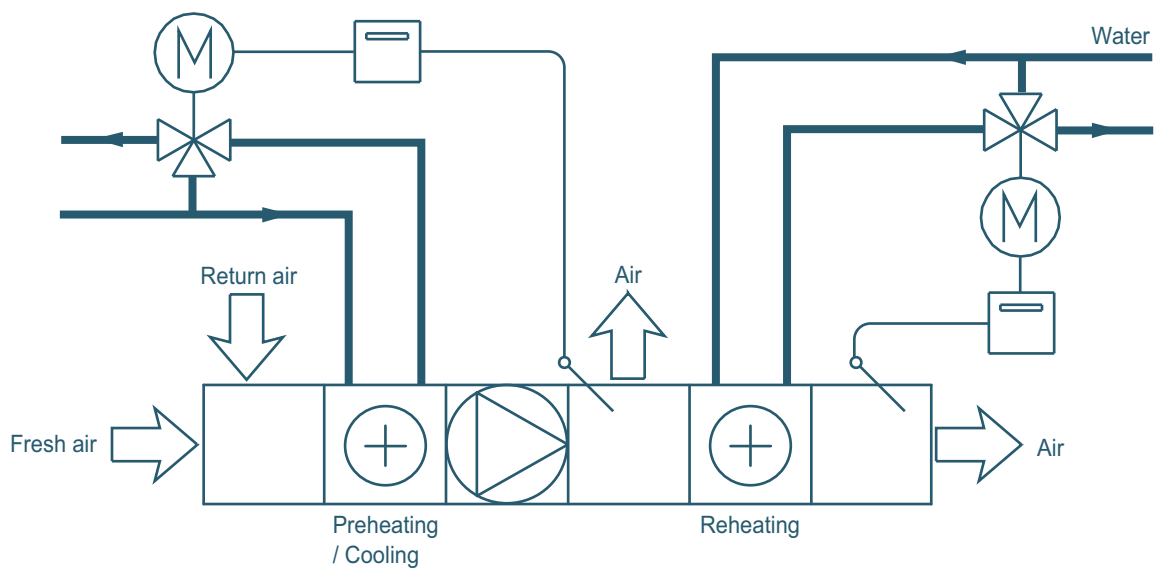

Heating system for fresh water generator

Solution 2, 4 and 7 (ref. page 4)

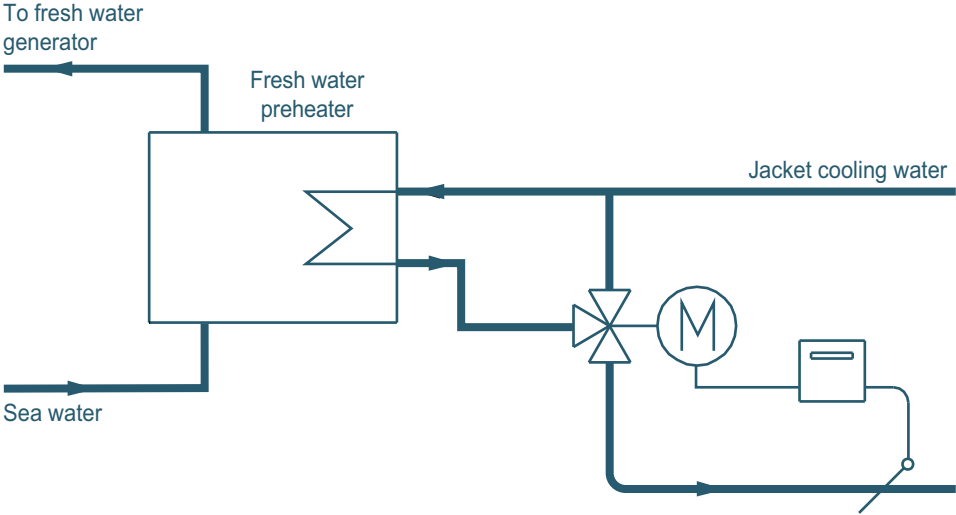

Pressure controls for fluids, steam and air

Solution 8 (ref. page 4)

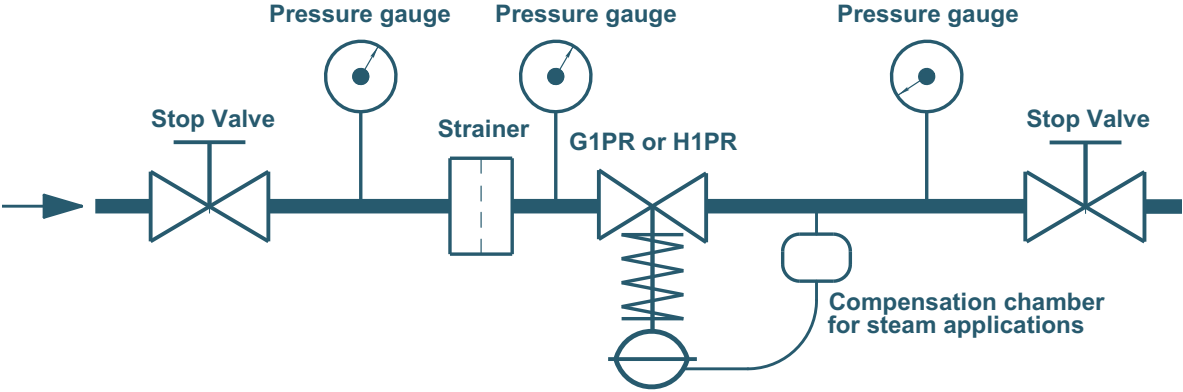

Complete control systems

Clorius Controls offers a complete range of tested and reliable equipment for control of heating, cooling and ventilation systems, all with the purpose of achieving the highest reliability and saving energy.

Specialists in selected areas



Maritime industry

Certified valves, thermostats and motors



Industry

Valves and thermostats for the regulation of heating, cooling and process heat



Controllers

Clorius Controls offers a wide range of electronic controllers for heating, cooling and ventilation systems. The controllers are available for systems in the maritime industry, general industry, institutions and residences. Clorius Controls offers controllers for simple stand-alone solutions or for larger BMS-plants.

Control valves

Clorius valves are simple and reliable for regulation of temperature and pressure differences in heating, cooling and ventilation systems for maritime industry, general industry, institutions and residences.



Motors

Clorius Controls offers a large program of conventional regulation motors and analogue motors. This includes special motors for maritime use, which are designed to withstand vibrations.

Thermostats

Self-acting thermostats from Clorius Controls are direct-acting and available with sensors for air or liquids. They are also available as safety thermostats for the protection of secondary pipe installations.



Pressure differential controllers

The controllers from Clorius Controls lower large and variable pump pressure to stabilize the flow in the plant.



Vendor:

Clorius
Controls A/S

Clorius Controls A/S
Tempovej 27
DK-2750 Ballerup
Denmark
Tel.: +45 77 32 31 30
Fax: +45 77 32 31 31
www.cloriuscontrols.com