

PPL / PPR

Pneumatic-Pneumatic Positioner

0-6.6.01-C

Page 1 of 4

PPL

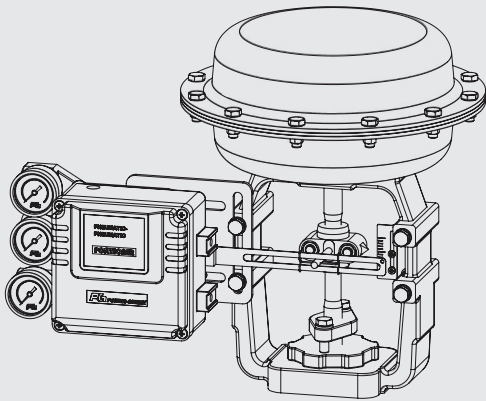

Robust valve control device giving a confidence in reliable performance and outstanding durability under harsh working environments

FEATURES

- Easy maintenance
- Precise calibration with simple SPAN and ZERO adjustments
- Simple conversion to direct acting or reverse acting
- 1/2 split range available
- Rugged aluminum housing with corrosion-resistant coating
- Vibration resistant design
- Stainless steel gauges standard
- Restricted pilot valve orifice kit for small actuators included

OPTIONS

- High temperature

SPECIFICATIONS

	PPL	
	Linear Type (Lever Feedback)	
	Single	Double
Input Signal	0.2-1.0 bar (3-15 psi) (Note 1,2)	
Supply Air Pressure	Max 7.0 bar (100 psi)	
Standard Stroke	10-80 mm (Note.3)	
Pneumatic Connections	PT(Rc) 1/4 or NPT 1/4	
Ambient Temperature	-20~ +70 °C (Note. 4)	
Pressure Gauge	Stainless steel	
Output Characteristics	Linear	
Linearity	Within ±1.0% F.S.	Within ±1.5% F.S.
Sensitivity	Within ±0.2% F.S.	Within ±0.5% F.S.
Hysteresis	Within ±1.0% F.S.	
Repeatability	Within ±0.5% F.S.	
Air Consumption	5 LPM (Sup. 1.4 bar)	
Flow Capacity	80 LPM (Sup. 1.4 bar)	
Body Material	Aluminium die-cast	
Weight	2.1 kg	

Note:

- 1) 1/2 split range is available for 3-9 psi input signal or 9-15 psi input signal
- 2) Please contact for 6-30 psi input signal
- 3) Feedback lever can be extended to stroke 80-150mm
- 4) High temperature option: up to +120°C

HOW TO ORDER

PPL — Feedback Lever Pressure Gauge Pilot Valve Orifice Connection Threads Operating Temperature Mounting Bracket

Description	Code	Description	Code
Feedback Lever:	A: Stroke 10 ~ 40mm B: Stroke 10 ~ 80mm C: Stroke 80 ~ 150mm	Connection Threads: (pneumatic)	3: PT(Rc) ¼ 4: NPT ¼
Pressure Gauge	1: 6 bar (90psi) 2: 10 bar (150psi)	Operating Temperature:	T: 70°C (standard) H: 120°C L: -40°C
Pilot Valve Orifice:	S: Standard (Actuator volume over 180 cm³) M: Small orifice (Ø 1.0 or Ø0.7) (Actuator volume 90~180cm³)	Mounting Bracket:	L: DIN/IEC 60534-6-1

DIMENSION SKETCH

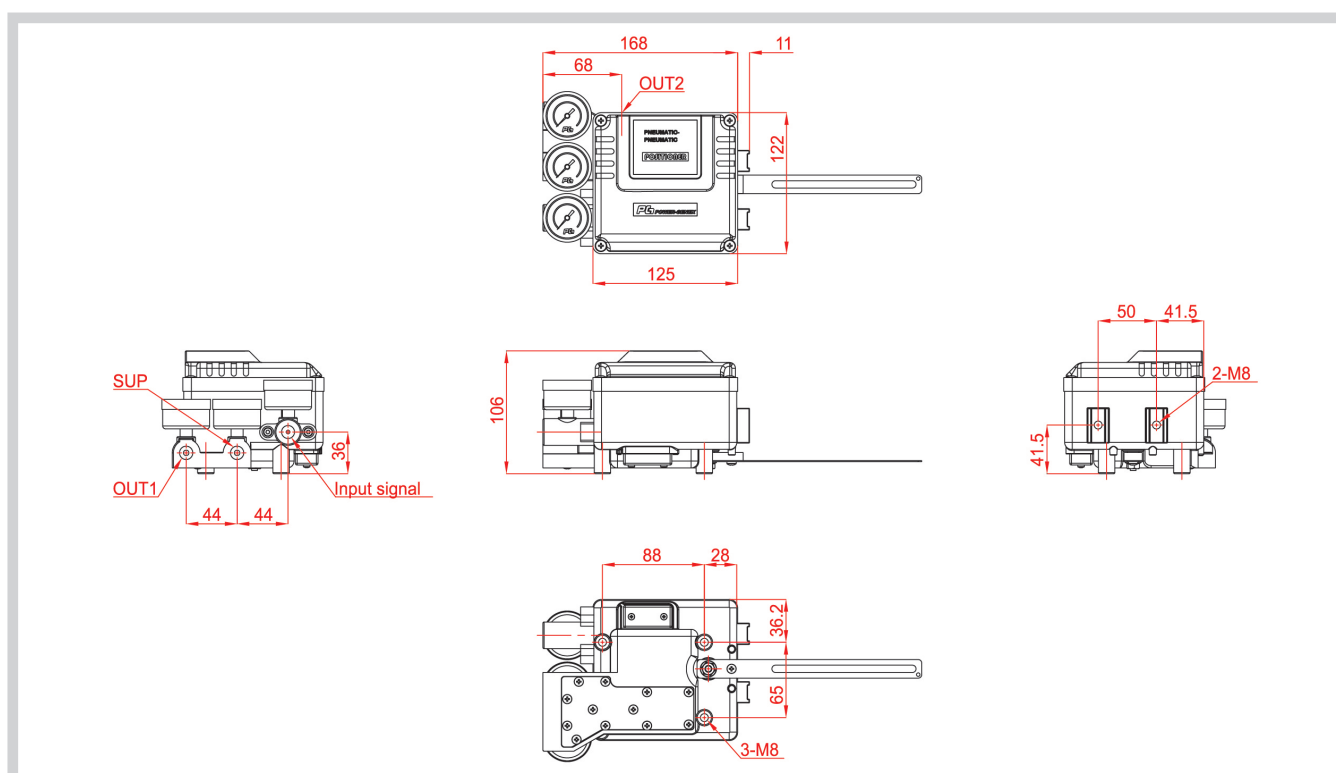

6

PPL / PPR

Pneumatic-Pneumatic Positioner

0-6.6.01-C

Page 3 of 4

PPR



With Dome Indicator



Robust valve control device giving a confidence in reliable performance and outstanding durability under harsh working environments

FEATURES

- Easy maintenance
- Precise calibration with simple SPAN and ZERO adjustments
- Simple conversion to direct acting or reverse acting
- 1/2 split range available
- Rugged aluminum housing with corrosion-resistant coating
- Vibration resistant design
- Stainless steel gauges standard
- Restricted pilot valve orifice kit for small actuators included

OPTIONS

- Position transmitter (4-20mA output signal)
- 2 x SPDT limit switch
- 2 x P&F proximity sensor NJ2-V3-N
- Visual dome indicator
- High temperature

SPECIFICATIONS

	PPR	
	Linear Type (Lever Feedback)	
	Single	Double
Input Signal	0.2-1.0 bar (3-15 psi) (Note 1,2)	
Supply Air Pressure	Max 7.0 bar (100 psi)	
Standard Stroke	60-100° (Note.3)	
Pneumatic Connections	PT(Rc) 1/4 or NPT 1/4	
Ambient Temperature	-20~ +70 °C (Note. 4)	
Pressure Gauge	Stainless steel	
Output Characteristics	Linear	
Linearity	Within ±1.0% F.S.	Within ±1.5% F.S.
Sensitivity	Within ±0.5% F.S.	
Hysteresis	Within ±1.0% F.S.	
Repeatability	Within ±0.5% F.S.	
Air Consumption	5 LPM (Sup. 1.4 bar)	
Flow Capacity	80 LPM (Sup. 1.4 bar)	
Body Material	Aluminium die-cast	
Weight	2.5 kg	

Note:

- 1) 1/2 split range is available for 3-9 psi input signal or 9-15 psi input signal
- 2) Please contact for 6-30 psi input signal
- 3) Operating angle can be adjusted to 0-60° or 0-100°
- 4) High temperature option: up to +120°C without feedback options
up to +85°C with feedback options

HOW TO ORDER

PPR	Feedback Lever	Pressure Gauge	Pilot Valve Orifice	Position Feedback	Connection Threads	Dome Indicator	Operating Temperature	Mounting Bracket

Description	Code
Feedback Lever:	A: NAMUR shaft (direct mounting) B: Fork lever M6 x 40L C: Fork lever other size on request
Pressure Gauge	1: 6 bar (90psi) 2: 10 bar (150psi)
Pilot Valve Orifice:	S: Standard (Actuator volume over 180 cm ³) M: Small orifice (Ø 1.0 or Ø0.7) (Actuator volume 90~180cm ³)
Position Feedback:	N: None (standard) O: Position transmitter (4~20mA output signal) L: 2 x SPDT limit switch P: 2 x proximity sensor P&F NJ2-V3-N M: O + L Q: O + P

Description	Code
Connection Threads: (pneumatic)	3: PT(Rc) ¼ 4: NPT ¼
Dome Indicator:	N: Flat indicator (standard) D: Dome indicator
Operating Temperature:	T: 70°C (standard) H: 120°C (without position feedback option) 85°C (with position feedback option) L: -40°C (without position feedback option)
Mounting Bracket - NAMUR Shaft Type: - Fork Lever Type	R: Multi-size NAMUR bracket for DIN VDI/VDE 3845 (130 x 30 x 50 bracket on request) F: DHCT bracket 80x30 for fork lever type E: Multi-size NAMUR bracket for Fork lever type (130 x 30 x 50 bracket on request)

DIMENSION SKETCH

