

Pneumatic Actuator

Series S

0-6.5.01-E

Page 1 of 2



TECHNICAL DATA

Material:	
- Body	Polyester coated steel
- Stem	Stainless steel 1.4301
- Tie rods	Stainless steel AISI 316
- Mounting plate	Polyester coated steel
- O-rings	NBR (Nitrile rubber)
- Diaphragm	Neoprene rubber w/terylene support
- Springs	Galvanized steel
Air quality	Dry and filtrated air, non aggressive gasses
Air supply	Max. 6 bar
Air supply connect.	1/8" RG Female
Temperature	-25°C to +115°C
Acting mode:	
- Type SC: Spring close / Air open (NC)	
- Type SO: Spring open / Air close (NO)	
Data sheet	0-6.5.01-E

APPLICATIONS

Pneumatic actuator for actuating and control of Clorius valves in various environments.

Relevant datasheets for accessories to the S actuators:

- Positioners	0.6.6.01, 0.6.6.02
- Filter regulators	0.6.8.01
- Controller	ER2000 0.4.6.01
- Sensor	PT100 0.4.7.01
- Pneumatic controller	580 0.6.7.01

DESIGN

Compact pneumatic actuator with rolling diaphragm and multiple internal compression springs for operating Clorius valves.

Reinforced rolling diaphragm guarantees long lifetime and reliable, safe operation. Maintenance or change of operating method does not require any special tools.

FUNCTION

The pneumatic actuator is powerful with a high control speed compared to electric actuators. The linear actuator has a simple and light design with a minimum of moving parts. The pneumatic actuator are also low maintenance due to the simple design and the few moving parts. The linear actuator is ideal for on/off and control functions of globe valves. The spring loaded actuator offers the possibility for a fail-safe function, the safety installation is low cost compared to example battery backup. The pneumatic actuator can be used in Eex areas, without extraordinary encapsulation or other precautions.

FEATURES

- Linear characteristic
- Multispring diaphragm actuator
- Compact design with low weight
- Diaphragm with vulcanised terylene support secures a long and safe life-time

DIMENSION SKETCH

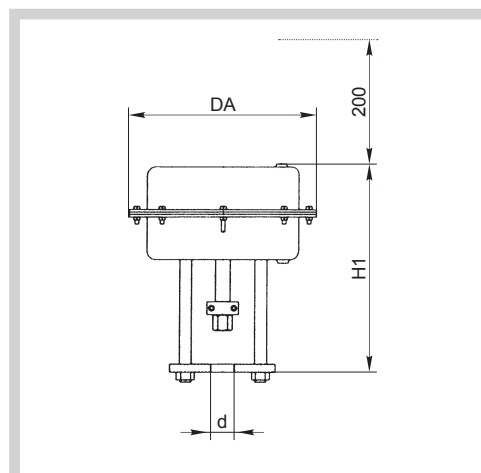

Type	d mm	DA mm	H1 mm	Travel mm
S16	25	160	237	20
S25	35	250	277,5	20
S34	32	340	350	33.5

Subject to change without notice.

Actuator	Type	Force	Travel (max)	Min. pressure to close valve	Min. pressure to open valve
S16	SC	1270 N	20 mm	-	1.1 Bar
	SO	925 N	20 mm	0.8 Bar	-
S25	SC	9090 N	20 mm	-	2.9 Bar
	SO	1740 N	20 mm	0.6 Bar	-
S34	SC	16100 N	33.5 mm	-	3.2 Bar
	SO	-	-	-	-

SELECTION OF LINEAR PNEUMATIC ACTUATORS

Valve size DN	Valve type	MAX P1 Inlet Pressure	Pneumatic actuator type
15	L1S, L1SB, M1F, M1FBN, G1F, G1FBN, H1F, H1FBN	16	S16
20	L2S, M1FBN, M2F, G1FBN, G2F, H1FBN, H2F	16	S16
	L1S, L1SB, L3S	10	
	M1F, G1F, H1F	7,5	
25	L1SB, L2S, M1FBN, M2F, G1FBN, G2F, G1FB, H1FBN, H2F, H1FB	16	S16
	M1F, G1F, H1F	5	
32	L1SB, L2S, G1FBN, G2F, H1FBN, H2F, M1FBN, M2F	16	S16
	L3S, M3F, G3F, H3F	10	
40	L2S, G2F, M2F, H2F	16	S16
	M1FBN, G1FBN, H1FBN	10	
	M3F, G3F, H3F	7,5	
	L3S	5	
50	L2S, G2F, M2F, H2F	16	S16
	M1FBN, G1FBN, H1FBN	16	
	L3S, M3F, G3F, H3F	16	
65	L3F, M1FBN, M2F, M3F, G1FBN, G2F, G3F, H1FBN, H2F	16	S25
80	L3F, M1FBN, M2F, M3F, G1FBN, G2F, G3F, H1FBN, H2F	16	S25
100	L3F, M2F, M3F, G2F, G3F, H2F	16	S25
125	L3F, M2F, M3F, G2F, G3F, H2F	16	S25
150	L3F, M2F, M3F, G2F, G3F, H2F	16	S25
200	L3F, M3F, G3F	16	S34
250	L3F, M3F, G3F	10	S34
300	L3F, M3F, G3F	10	S34 (on request)

Where the differential pressure is higher than noted S16 must be replaced with S25.
Where manual override is needed S16 must be replaced with S25

